

SAMSUNG

DIGITAL HOME
THEATER SYSTEM
HT-DM550

THIS APPLIANCE IS MANUFACTURED BY:

SAMSUNG

ELECTRONICS

Instruction Manual

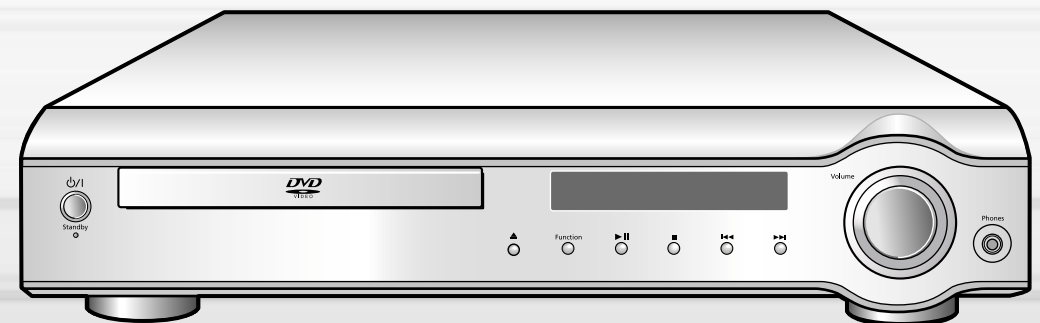

AH68-01142B



Safety Warnings

CLASS 1 LASER PRODUCT
 KLASSE 1 LASER PRODUKT
 LUOKAN 1 LASER LAITE
 KLASS 1 LASER APPARAT
 PRODUCTO LASER CLASE 1

CAUTION
 RISK OF ELECTRIC SHOCK.
 DO NOT OPEN

CAUTION:
 TO REDUCE THE RISK OF ELECTRIC SHOCK, DO NOT REMOVE REAR COVER. NO USER SERVICEABLE PARTS INSIDE. REFER SERVICING TO QUALIFIED SERVICE PERSONNEL.

CLASS 1 LASER PRODUCT
 This Compact Disc player is classified as a CLASS 1 LASER product.

Use of controls, adjustments or performance of procedures other than those specified herein may result in hazardous radiation exposure.

CAUTION-INVISIBLE LASER RADIATION WHEN OPEN AND INTERLOCKS DEFEATED, AVOID EXPOSURE TO BEAM.

- This symbol indicates that dangerous voltage which can cause electric shock is present inside this unit.
- This symbol alerts you to important operating and maintenance instructions accompanying the unit.

WARNING: To reduce the risk of fire or electric shock, do not expose this appliance to rain or moisture.

CAUTION: TO PREVENT ELECTRIC SHOCK, MATCH WIDE BLADE OF PLUG TO WIDE SLOT, FULLY INSERT.

Wiring the Main Power Supply Plug(UK Only)

IMPORTANT NOTICE

The main lead on this equipment is supplied with a moulded plug incorporating a fuse. The value of the fuse is indicated on the pin face of the plug and if it requires replacing, a fuse approved to BS1362 of the same rating must be used.

Never use the plug with the fuse cover removed. If the cover is detachable and a replacement is required, it must be of the same colour as the fuse fitted in the plug. Replacement covers are available from your dealer.

If the fitted plug is not suitable for the power points in your house or the cable is not long enough to reach a power point, you should obtain a suitable safety approved extension lead or consult your dealer for assistance.

However, if there is no alternative to cutting off the plug, remove the fuse and then safely dispose of the plug. Do not connect the plug to a main socket as there is a risk of shock hazard from the bared flexible cord.

Never attempt to insert bare wires directly into a main socket. A plug and fuse must be used at all times.

IMPORTANT

The wires in the main lead are coloured in accordance with the following code:-

BLUE = NEUTRAL BROWN = LIVE

As these colours may not correspond to the coloured markings identifying the terminals in your plug, proceed as follows:-

The wire coloured BLUE must be connected to the terminal marked with the letter N or coloured BLUE or BLACK.
 The wire coloured BROWN must be connected to the terminal marked with the letter L or coloured BROWN or RED.

WARNING: DO NOT CONNECT EITHER WIRE TO THE EARTH TERMINAL WHICH IS MARKED WITH THE LETTER E OR BY THE EARTH SYMBOL , OR COLOURED GREEN OR GREEN AND YELLOW.

Precautions

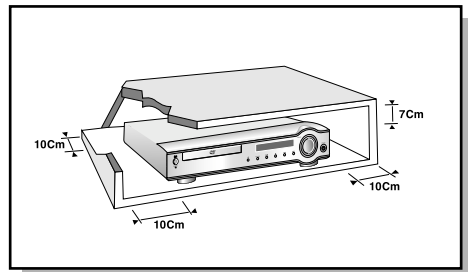

Ensure that the AC power supply in your house complies with the identification sticker located on the back of your player. Install your player horizontally, on a suitable base (furniture), with enough space around it for ventilation (3-4inches). Make sure the ventilation slots are not covered. Do not stack anything on top of the player. Do not place the player on amplifiers or other equipment which may become hot. Before moving the player, ensure the disc tray is empty. This player is designed for continuous use. Switching off the DVD player to the stand-by mode does not disconnect the electrical supply. In order to disconnect the player completely from the power supply, remove the main plug from the wall outlet, especially when left unused for a long period of time.

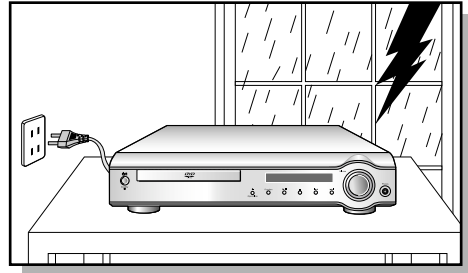
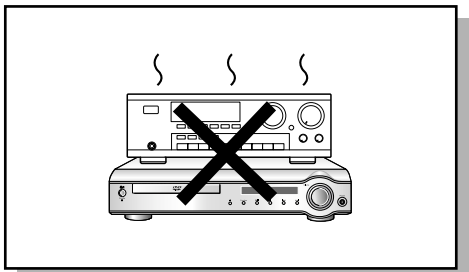

During thunderstorms, disconnect the main plug from the socket. Main voltage peaks due to lightning could damage the unit.

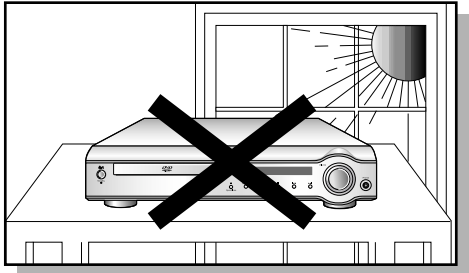

Do not expose the unit to direct sun radiation or other heat sources. This could lead to overheating and malfunction of the unit.

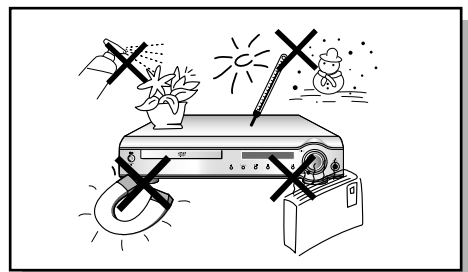

Protect the player from moisture(dripping or splashing and that no objects filled with liquids,such as vases, shall be placed on the player), and excess heat(e.g.fireplace) or equipment creating strong magnetic or electric fields (i.e.speakers...) disconnect the power cable from the mains electricity supply if the player malfunction. Your player is not intended for industrial use but for domestic purposes only. Use of this product is for personal use only. Condensation If your player or disc have been stored in a cold atmosphere. as for example during transportation in the winter, wait for approximately 2 hours until they have reached room temperature.

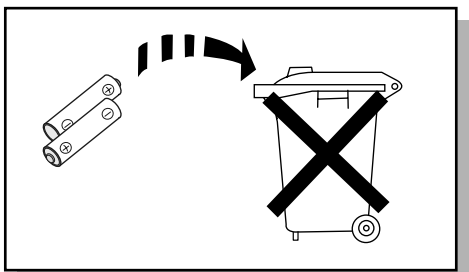

The battery used in this product contains the chemicals that are harmful to the environment. Do not dispose of batteries in the general household waster. It is recommended that the replacement of the battery should be done by technician.



Contents



DVD (Digital Versatile Disc) offers fantastic audio and video, thanks to Dolby Digital surround sound and MPEG-2 video compression technology. Now you can enjoy these realistic effects in the home, as if you were in a movie theater or concert hall.



DVD players and the discs are coded by region. These regional codes must match in order for the disc to play. If the codes do not match, the disc will not play. The Region Number for this player is given on the rear panel of the player. (Your DVD player will only play DVDs that are labeled with identical region codes.)

Do not use the following types of disc!

- LD, CD-G, CD-I, CD-ROM and DVD-ROM cannot be played on this player. If such discs are played, a "WRONG DISC FORMAT" message appears on the TV screen.
- DVD discs purchased abroad may not play on this player. If such discs are played, a "WRONG REGION CODE" message appears on the TV screen.

Copy Protection

- Many DVD discs are encoded with copy protection. Because of this, you should only connect your DVD player directly to your TV, not to a VCR. Connecting to a VCR results in a distorted picture from copy-protected DVD discs.
- This product incorporates copyright protection technology that is protected by methods claims of certain U.S. patents and other intellectual property rights owned by Macrovision Corporation and other rights owners. Use of this copyright protection technology must be authorized by Macrovision Corporation, and is intended for home and other limited viewing uses only unless otherwise authorized by Macrovision Corporation. Reverse engineering or disassembly is prohibited.

CHAPTER 1. PREPARATION

Safety Warnings	1
Precautions	2
Description	5
Remote Control	7
Listening on headphones	8

CHAPTER 2. CONNECTIONS

Connecting the Speakers	9
Connect Video to TV	10
Connecting the FM and AM(MW/LW) Antennas	11
AUX Connections	12
Controlling a TV with the Remote	13
Connecting your System to the Power Supply	13
Before Using the DVD Player	14

CHAPTER 3. OPERATION

DVD Playback	15
MP3-CD Playback	17
Forward/Reverse Searching	19
Slow Playback/Checking the Remaining Time	20
Repeat Playback	21
Using Disc Menu/Title	22
Selecting the Audio Language/Subtitle Language	23
Zoom/Angle Functions	24
Program Playback	25
Sleep/D.R.C Function	27

CHAPTER 4. SETUP

Setting up the Language Features	28
System Setup	29
Speaker Setup	31
To set up Speaker Balance	33
Creating Realistic Sound Fields	34
Dolby Pro Logic II decoder	35
DSP (Digital Signal Processor) Modes	37
To increase Effect level	38
Adjusting DSP Sound Parameters	38

CHAPTER 5. RADIO OPERATION

Listening to the Radio	39
Presetting stations	40
About RDS broadcasting	41

CHAPTER 6. MISCELLANENOUS

Troubleshooting	43
Cautions on Handling and Storing Discs	45
Disc Type and Protection	46
Specifications	47
Reference	48

Description

Front Panel

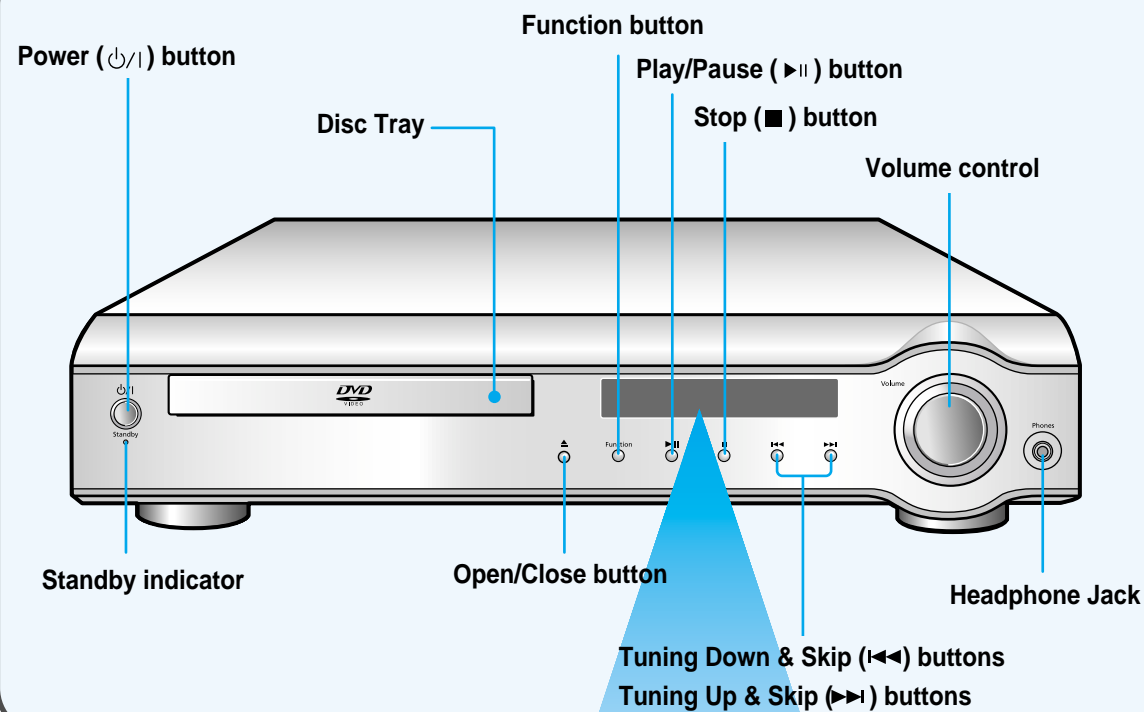

Display

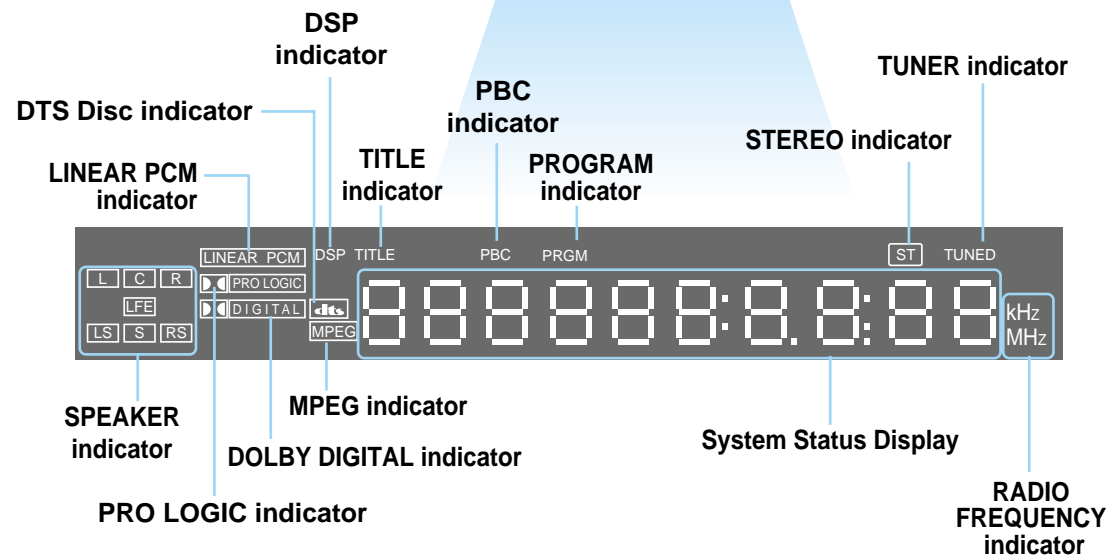

Rear Panel

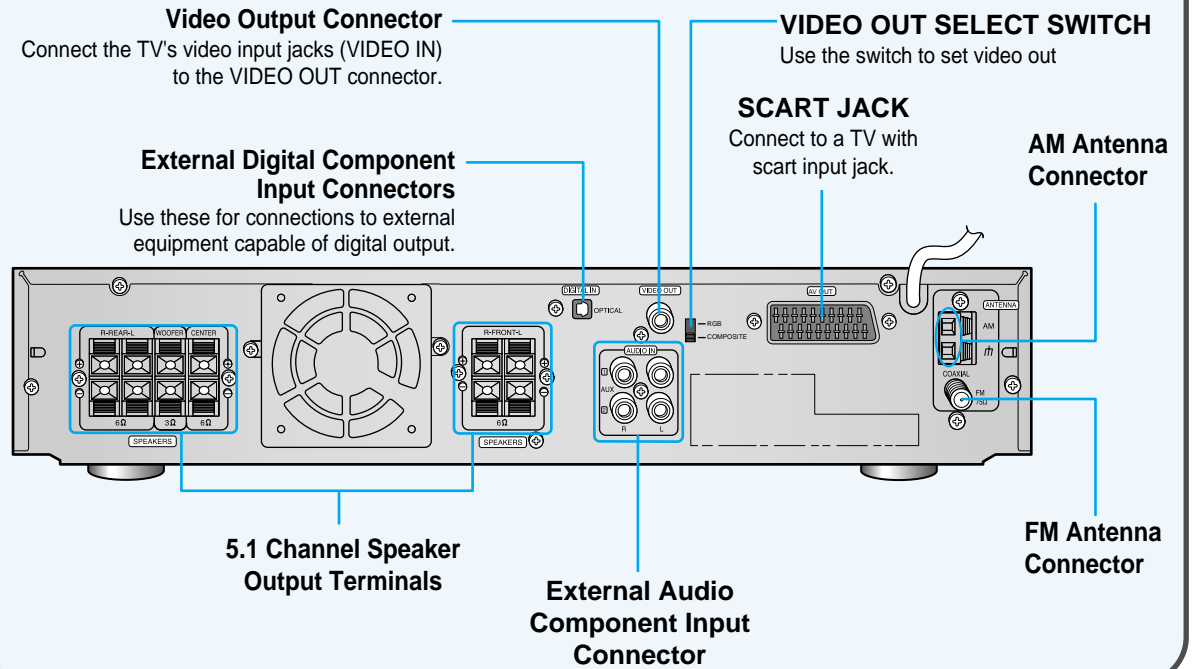

Accessories

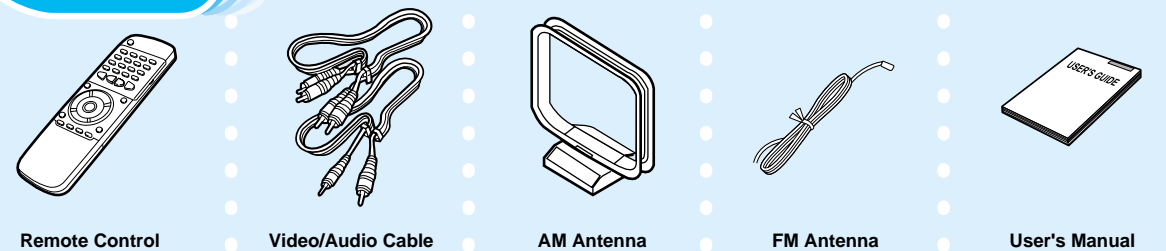

Remote Control Unit

DVD POWER button

- DVD button
- TUNER button
- AUX button
- Open/Close button

- Title button
- Menu button
- Audio MO/ST(mono/stereo) button
- Subtitle button
- Display button
- Return button

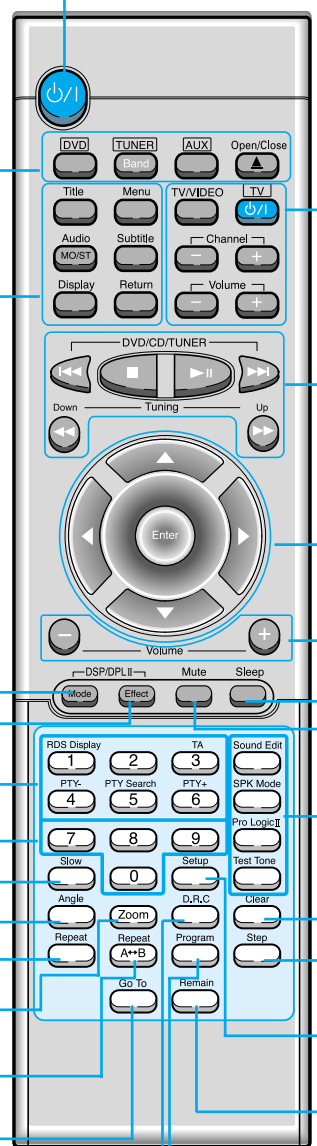

- TV Power button
- TV/VIDEO button
- TV Channel Selection button
- TV Volume Control button

- Play/Pause button
- Stop button
- Tuning Preset/CD Skip button
- Tuning Up/Down/CD Search button

Direction/Enter button

Volume Control buttons
Speaker output volume control

Sleep button
Mute button

- Sound Edit button
- SPK Mode button
- Pro Logic II button
- Test Tone button

Clear button

Step button

Setup button

Remain button

Program button

DSP/DPL II Mode button
DSP/DPL II Effect button

RDS Selection button

Number(0~9) buttons

Slow button

Angle button

Repeat button

Zoom button

Repeat A↔B button

Go To button

D.R.C button

Insert Remote Batteries

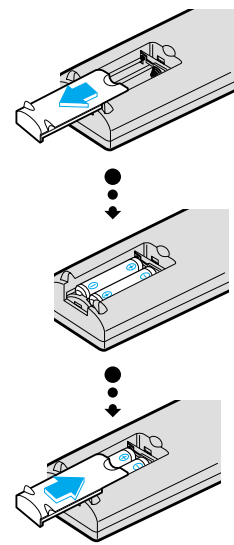

- 1 Remove the battery cover on the back of the remote by pressing down and sliding the cover in the direction of the arrow.
- 2 Insert two 1.5V AAA batteries, paying attention to the correct polarities (+ and -).
- 3 Replace the battery cover.

CAUTION

- Follow these precautions to avoid leaking or cracking cells:
- Place batteries in the remote control so they match the polarity:(+) to (+)and (-)to (-).
 - Use the correct type of batteries.Batteries that look similar may differ in voltage.
 - Always replace both batteries at the same time.
 - Do not expose batteries to heat or flame.

Range of Operation of the Remote Control

The remote control can be used up to approximately 23 feet/7 meters in a straight line. It can also be operated at a horizontal angle of up to 30° from the remote control sensor.

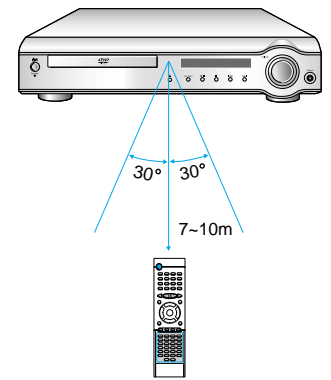

To open the remote control cover, push the top of the cover, then slide downward.

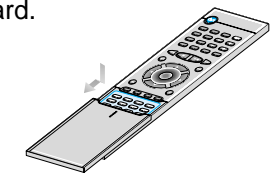

PREPARATION

Listening on headphones

Listening on headphones

- Use headphones (not supplied) for private listening pleasure.
- Connect the headphones to the HEADPHONES jack of the front panel.**
- No sound is produced from the speakers.
 - To prevent hearing damage, do not raise the volume level excessively when using headphones.

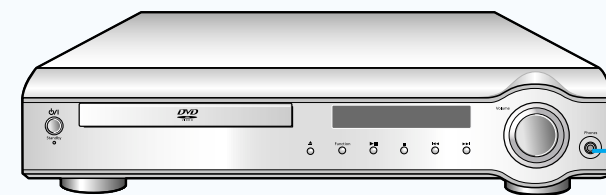

HEADPHONE jack

Connecting the Speakers

- Connect the satellite speakers, center speaker, and subwoofer to the terminals on the rear panel using speaker cords supplied.
- Connect the red cord to the red (+) terminal and the black cord to the black (-) terminal.

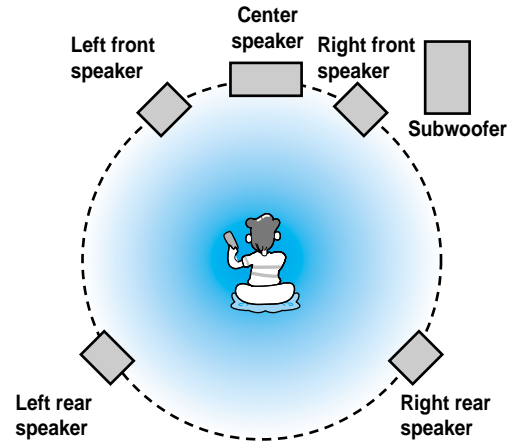

- 1 Press and hold the terminal tab.
- 2 Insert the speaker cord.
- 3 Release the finger.

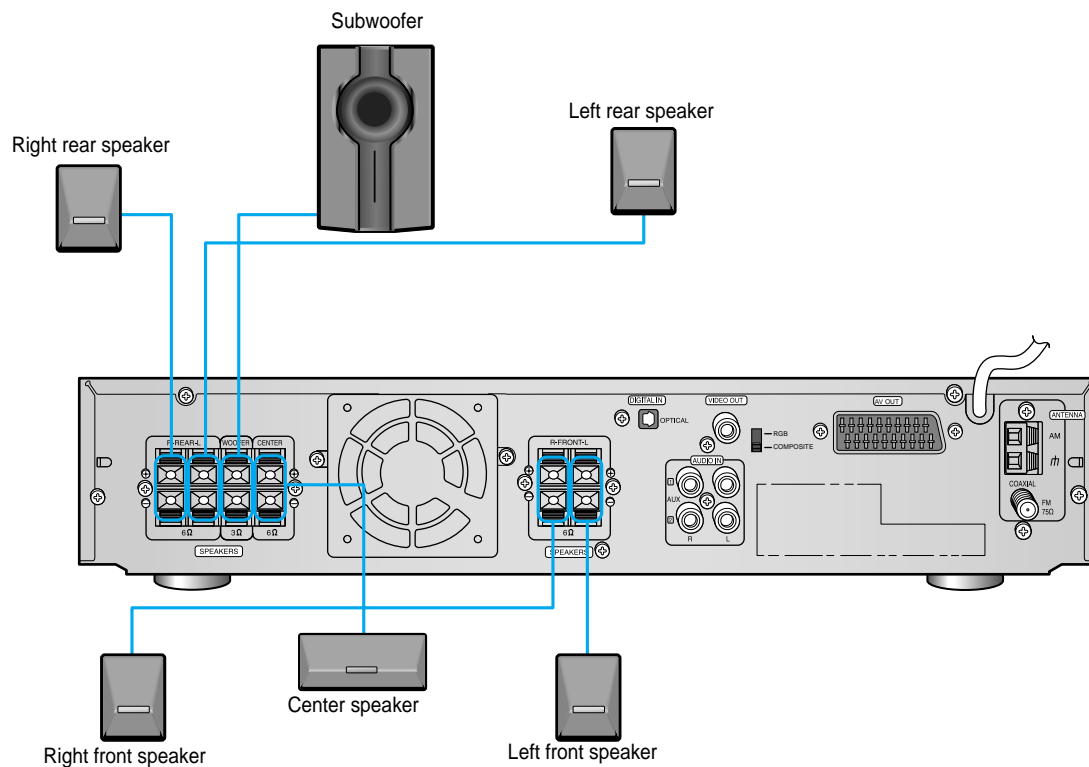
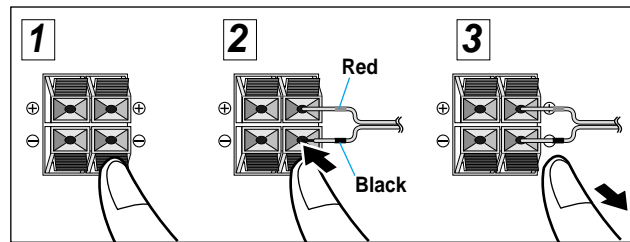

Note • For details on the “Ideal Speaker Placement” see page 32.

Connect Video to TV

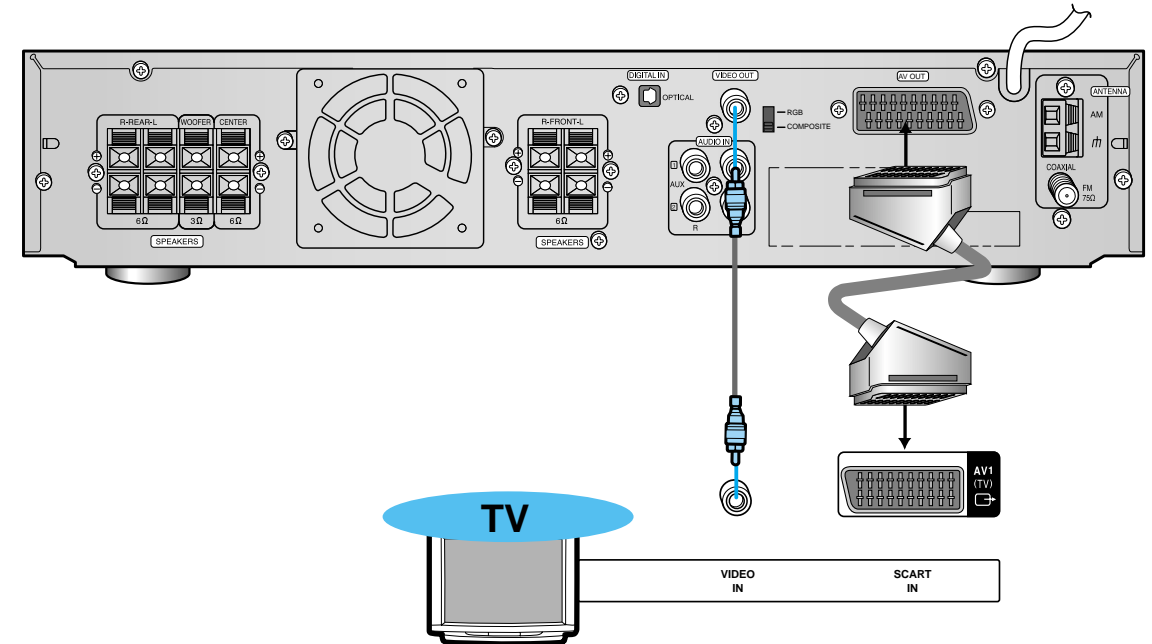

Composite Video (Good Quality)

Connect the supplied video cable from the VIDEO OUT jack on the back panel of the system to the VIDEO IN jack on your television.

Scart (Best Quality)

If your television is equipped with an SCART input, connect an Scart Jack (not supplied) from the AV OUT jack on the back panel of the system to the SCART IN jack on your television.

For using the SCART cable

- If Scart is equipped for your TV, set RGB-COMPOSITE selector of the center unit to RGB. You can get a better picture quality by using Scart setting.
- If Scart is not equipped for your TV, set RGB-COMPOSITE selector to COMPOSITE.



Note • On the rear panel SCART cable is indicated as “AV OUT.”

Connecting the FM and AM(MW/LW) Antennas

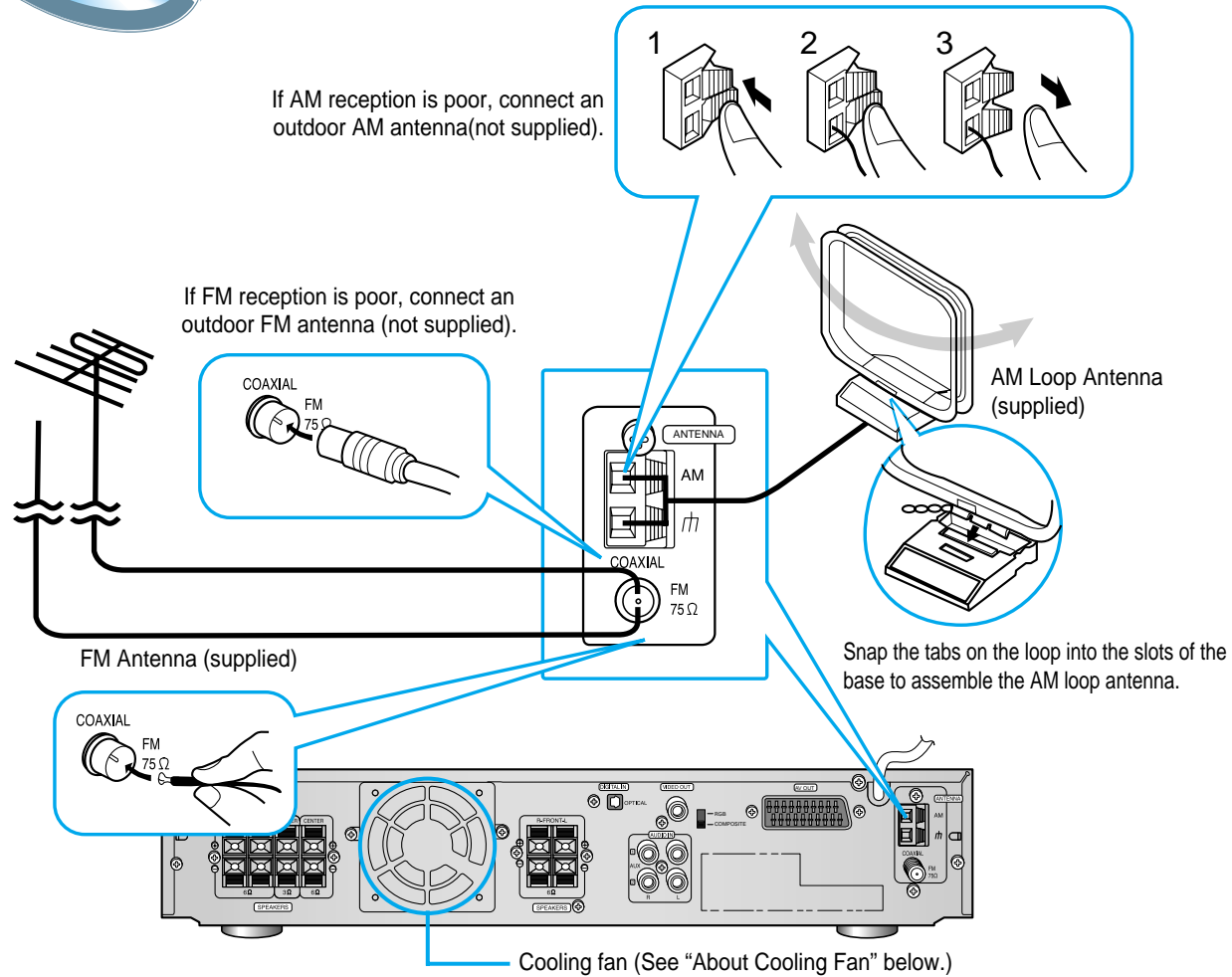

FM antenna connection

1. Connect the FM antenna supplied to the FM 75Ω COAXIAL terminal.
2. Slowly move the antenna wire around until you find a location where reception is good, then fasten it to a wall or other rigid surface.

- If reception is poor, connect an outdoor antenna. Before attaching a 75Ω coaxial cable (with a standard type connector), disconnect the supplied FM antenna.

AM(MW/LW) antenna connection

1. Connect the AM loop antenna supplied to the AM and ⏏ terminals.
2. If reception is poor, connect an outdoor single vinyl-covered wire to the AM terminal. (Keep the AM loop antenna connected).

(About the cooling fan)

A cooling fan is mounted on the rear panel of the center unit to prevent abnormal temperature inside the center unit, thus assuring normal operation. The cooling fan automatically starts rotating to supply external cool air to the inside of the center unit when the internal temperature exceeds the specified limit.

For safety, observe the following carefully.

- Make sure there is good ventilation around the center unit. Poor ventilation could overheat and cause damage.
- DO NOT block the cooling fan and the ventilation openings or holes. (If they are blocked by a newspaper or cloth, etc., the heat may not be able to escape.)

AUX Connections

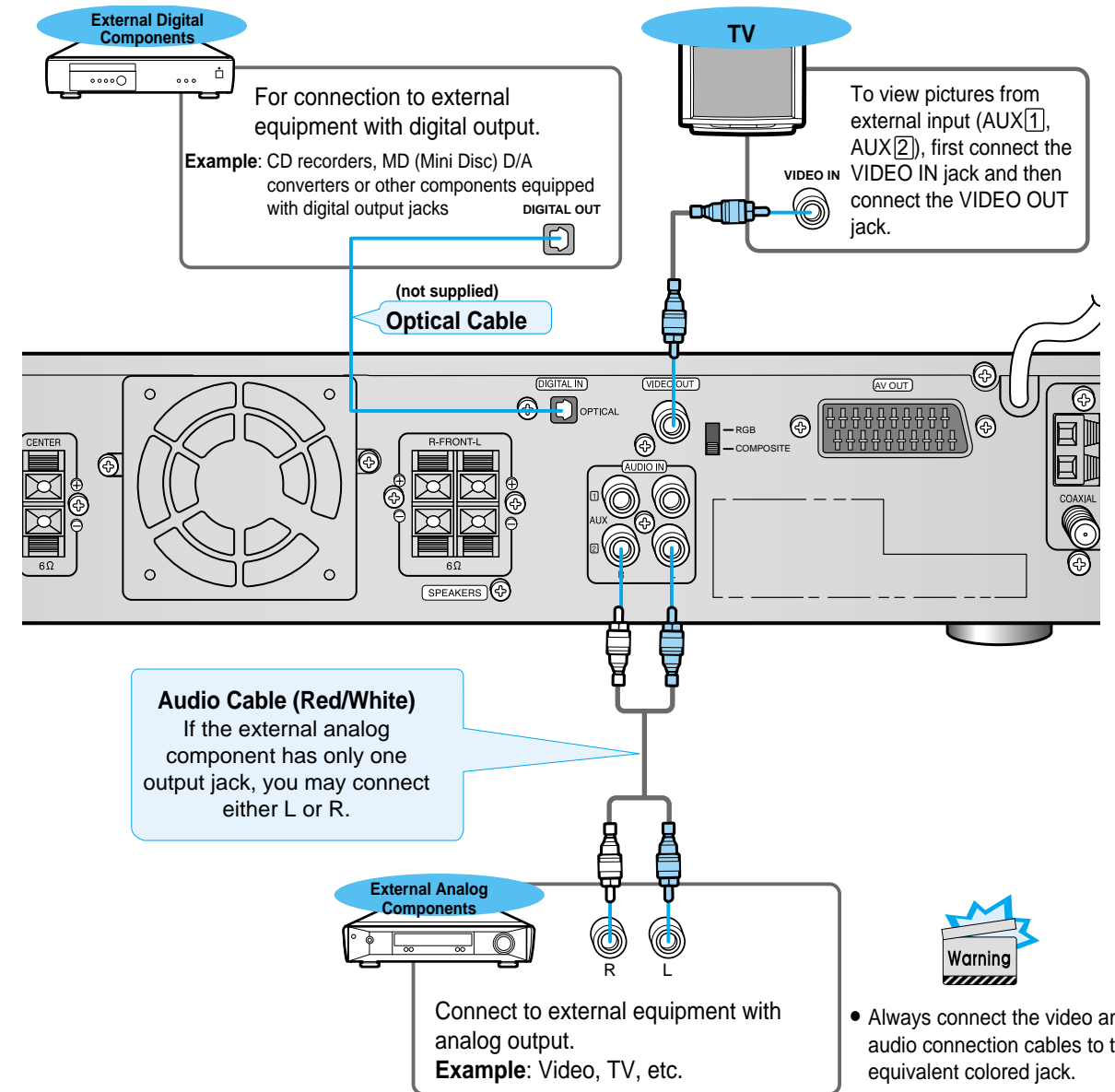





To Play External Digital/Analog Equipment

- Press **AUX** on the remote control to select DIGITAL IN, AUX1, or AUX2.
- Press **Function** on the main unit to select DIGITAL IN, AUX1, or AUX2.
- Each time the button is pressed the mode switches as follows: FM → AM → DVD → DIGITAL IN → AUX 1 → AUX 2.

Controlling a TV with the Remote

You can use the remote control to operate other manufactures' TV.

- 1** Turn on the TV.
- 2** Point the DVD's remote at the TV.
- 3** While holding the  button down, enter the code for your brand.
 - If there is more than one code listed in the table, enter one at a time to determine which code works.
 - example :** For SAMSUNG 1TVs
While holding down the  button, enter  +  .

Manufacturer	CODES
Samsung	01~06,32
Akai	12
Fisher	12
Grundig	09,17,21
Hitachi	11,13,14,24
JVC	32
LG	02,30
Mitsubishi	02,16
Mival	29
Nokia	23
Nordmende	13,14,24
Panasonic	08,23~27
Philips	02,20,22
Saba	13,14,22~24
Sanyo	12,16
Schneider	02
Sharp	10,31
Sony	15,16
Telefunken	14,24,28
Thomson	13,14,24,33,34
Toshiba	07,16~19,21

- 4** If the TV turns off, setup is complete.
 - Now, you can perform the following operations on the TV.

TV 	: Turn on or off the TV.
VOLUME +/-	: Adjust the volume.
TV/VIDEO	: Set the input mode (either TV or VIDEO)
CHANNEL +/-	: Change the channels.





Note • Manufacturers' codes are subject to change without notice. If they are changed, this remote control cannot operate the equipment.

Before Using the DVD Player

Your DVD player is capable of playing DVD, VCD, and CD discs. User instructions may vary depending on the type of disc. Read the instructions carefully before use.

- 1** Turn on the power to your DVD player and TV.

Preparations before use

 
- 2** Select a video mode by pressing the TV/VIDEO button.
 
- 3** Press the DVD button to select the DVD input function.
 

- Note**
- The "WAIT" message that appears on the display for about 4~5 seconds when turning on the power or selecting a DVD function indicates a stabilization period for optimizing the condition of your DVD player. While the message is being displayed, other buttons remain inactive.
 - When the power is not turned on, press down the **Stop** (■) button on the main unit for over 5 seconds. The product will be initialized to its optimum state.
 - As to some operational features such as the Speaker mode, Test tone, Volume, etc. your DVD player will not display their operation on the TV screen.

CONNECTIONS

Connecting your System to the Power Supply

The AC Cord must be plugged into an appropriate socket.

Before plugging your system into an AC outlet, you must check the voltage.

1. Plug the AC Cord on the rear of the system into an appropriate outlet.
2. Press the On/Standby button to switch your DVD Player system on.

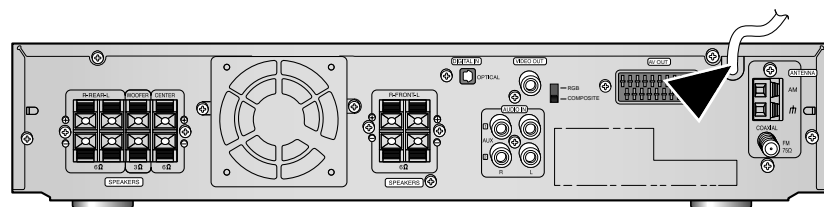

TV Broadcast System

- This device is designed to work with the PAL video format.
- For normal playback, the video format a DVD disc is recorded in must coincide with your TV's video format.

DVD Playback

- 1**

Press the **Open/Close** (▲) button to open the disc tray.

 - The button is located only on the Front Panel of the player (not on the remote).
- 2**

Insert a DVD disc.



 - Place a disc gently into the tray with the disc's label facing up.
- 3**

Press the **Open/Close** (▲) button again to close the disc tray.

 - Playback starts automatically.

Using the On-Screen Display

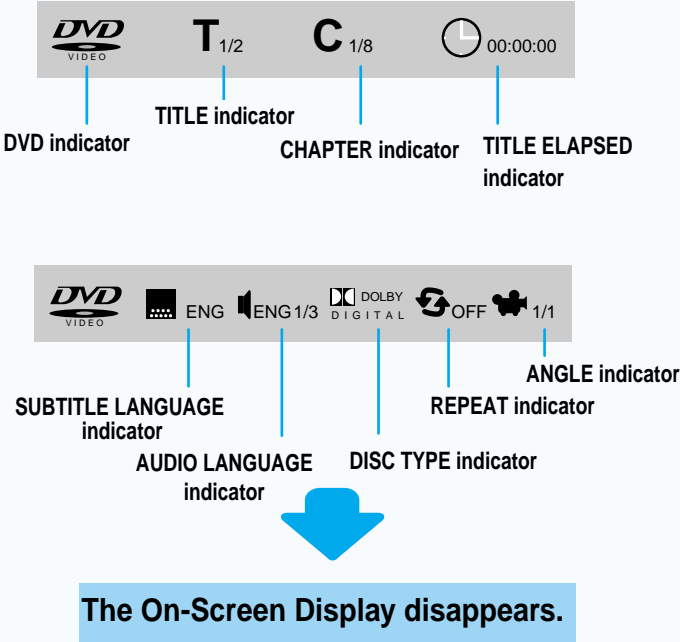
Press the **Display** button on the remote.

The OSD menu displays the following information:

- DVD indicator**: DVD VIDEO
- TITLE indicator**: T 1/2
- CHAPTER indicator**: C 1/8
- TITLE ELAPSED indicator**: 00:00:00
- SUBTITLE LANGUAGE indicator**: ENG
- AUDIO LANGUAGE indicator**: ENG 1/3
- DISC TYPE indicator**: DOLBY DIGITAL
- REPEAT indicator**: OFF
- ANGLE indicator**: 1/1

Pressing the **Display** button again causes the OSD to disappear.

Pausing Playback

Press the **Play/Pause** (▶||) button during playback.

- To resume, press the Play/Pause (▶||) button again.

Note

- Depending on the disc, the initial disc information screen may look different from disc to disc.
- When playing a DVD containing MPEG format, video may not be reproduced correctly and you may get picture distortion.

Stopping Playback

Press the **Stop** (■) button during playback.

- During playback, when the Stop (■) button is pressed, the position is stored in the memory, and ■ STOP is shown on the display. When the Play/Pause (▶||) button or Return button is pressed subsequently, playback resumes from the position at which it was stopped.
- If the Stop (■) button is pressed a second time, the 'resume play' memory function is canceled, and ■ STOP is shown on the display. When the Play/Pause (▶||) button is pressed, playback starts from the beginning.

What is a Title?
A movie contained in a DVD disc.

What is a Chapter?
Each Title on a DVD disc is divided into several smaller sections called "chapters".

Turning the sound off temporarily?

Press the **Mute** button during playback.

- This operation may be useful when you need to greet the guests or answer the telephone.

Note If the player is left for more than 3 minutes in pause mode, it will stop.

MP3-CD Playback

This system has a built-in MP3 decoder.
You can play back MP3 tracks (files) recorded on CD-Rs, CD-RWs, and CD-ROMs.

What is MP3? MP3 is an abbreviation of Motion Picture Experts Group (or MPEG) Audio Layer 3. MP3 is simply a file format with a data compression ratio of 1:10 (128 Kbps*). That means, by using MP3 format, one CD-R or CD-RW can contain 10 times as much data volume as a regular CD can.

Starting Playback

- It is recommended you turn on your TV when playing back an MP3-CD.

1

Press the **Open/Close** (▲) button to load a disc.

2

Press the **Play/Pause** (▶||) button.

- After detecting the disc, playback starts.
- The on-screen bar and the contents recorded on the MP3-CD will be shown on the TV if it is turned on.

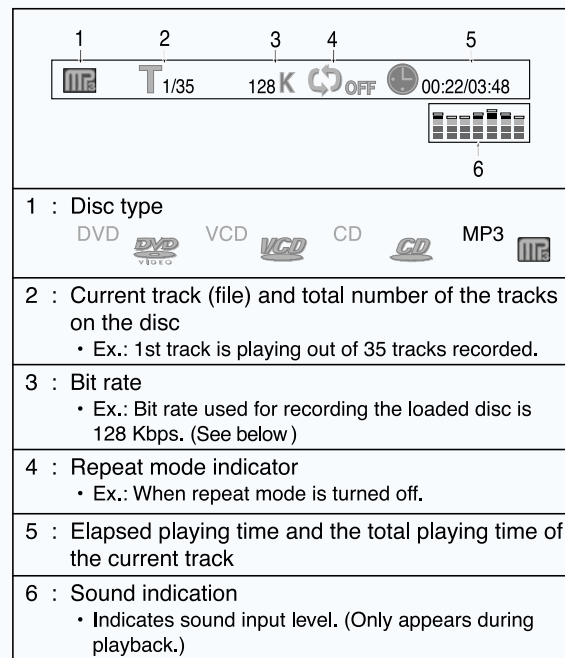
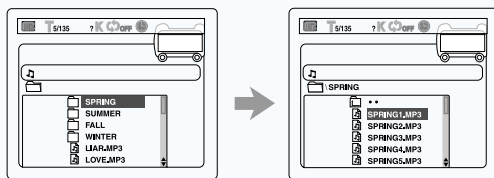

To stop during playback

- Press the **Stop** (■) button.

CD-R MP3 DISC

- Only CD-R discs with MP3 files in ISO 9660 or Joliet format can be played.
- The file name of the MP3 file may not be longer than 8 characters and should contain no blank spaces or special characters.
- Use discs recorded with a compression/decompression data rate greater than 128Kbps.
- Only files with the ".mp3" and ".MP3" extensions can be played.
- Only a consecutively written Multisession disc can be played. If there is a blank segment in the Multisession disc, the disc can be played only up to the blank segment.
- If the disc is not closed, it will take longer to begin playback and not all of the recorded files may be played.
- For files encoded in Variable Bit Rate (VBR) format, i.e. files encoded in both low bit rate and high bit rate (e.g., 32Kbps ~ 320Kbps), the sound may skip during playback.



Note Depending on the recording mode, some MP3-CD cannot be played.

Operations Using the On-Screen Display

Turn on your TV when playing back an MP3 disc.

When the loaded MP3 disc is recognized, the following on-screen display appears on the TV screen.
(The contents of this on-screen display vary according to the disc — the way MP3 tracks were recorded on the disc.)

Button	To do
ENTER, ▶	Start playback or go into a directory.
▲/▼	Select a track or directory.

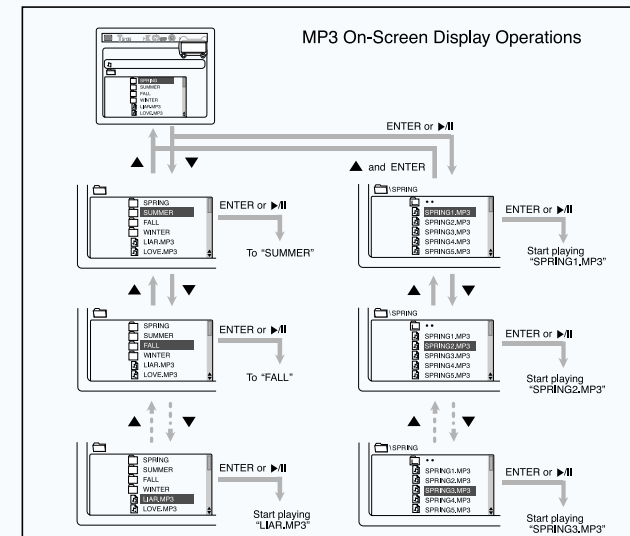

CD-R/RW playback compatibility

- Your DVD player can also play CD-R and CD-RW discs recorded in digital audio format. When recording your own CD-R or CD-RW discs, make sure that the recording session is properly terminated, or they will not be playable. (Depending on disc properties and recording quality, some CD-R/RWs may not be playable.)
- CD-RW has a lower reflection rate than CD-R media and consequently it will take a longer to read CD-R discs.
- CD-RW discs recorded at high speed tend to be difficult for the DVD player to read. If the recording speed for the CD-RW disc is not predetermined, write it at low speed.

Repeating Playback

On an MP3 disc, Repeat A↔B cannot be used. You can enjoy only repeat play.

Press the Repeat button.

The indication corresponding to the selected mode appears on the TV screen.

- Each time you press the button, repeat mode changes as follows:

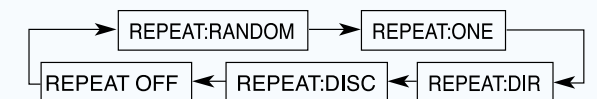

REPEAT:RANDOM

: All tracks recorded on the disc will be played once in random order.

REPEAT:ONE

: Current track will be repeated.

REPEAT:DIR

: Tracks in the current directory will be repeated.

REPEAT:DISC

: All tracks on the disc will be repeated.

REPEAT OFF

: Repeat play is canceled. (Normal play is resumed.)

Forward/Reverse Searching

During playback, you can search quickly through a chapter or track for a specific scene or tune.

High-Speed Playback

Press the ◀◀ and ▶▶ button.

Each time the ◀◀ button is pressed

- ◀◀ X 2
- ◀◀ X 4
- ◀◀ X 8
- ◀ PLAY

Each time the ▶▶ button is pressed

- ▶▶ X 2
- ▶▶ X 4
- ▶▶ X 8
- ▶ PLAY

DVD VCD CD

Skipping through a Chapter

Press the ◀◀ and ▶▶ button.

- Each time the button is pressed during playback, it moves to the next or previous chapter and plays it.

DVD VCD CD

Playing Frame by Frame

Press the Step button.

- The picture moves forward one frame each time the button is pressed.

Note No sound is heard during high-speed playback, slow playback, and step motion.

Slow Playback/Checking the Remaining Time

Playing Slowly

Press the Slow button.

Each time the Slow button is pressed

- ▶ SLOW 1/2
- ▶ SLOW 1/4
- ▶ PLAY

DVD VCD

VCD The slow playback speed changes and the selections (1/2X, 1/4X, 1/8X, 1/16X and normal play) are repeated.

Checking the Remaining Time

Press the Remain button.

- For checking check the total time and the remaining time of a title or chapter being played.

Each time the Remain button is pressed

DVD

- TITLE TIME
- REMAIN TIME : TITLE
- CHAPTER TIME
- REMAIN TIME : CHAPTER

VCD CD

- TRACK TIME
- REMAIN TIME : TRACK
- DISC TIME
- REMAIN TIME : DISC

Repeat Playback

Repeat playback allows you to repeat a chapter, title, or track.

Using Disc Menu/Title

Playing Repeatedly

Press the Repeat button.

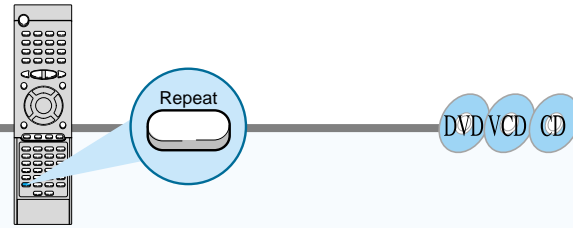

Each time the Repeat button is pressed

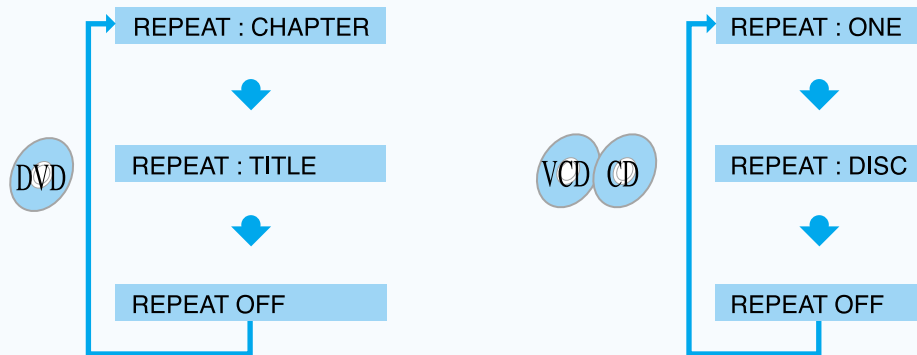

Note • Repeat playback operation is not possible with version 2.0 VCD discs if PBC is turned on. To operate this feature, press the MENU button, and then select "PBC OFF".

To Select the Disc Menu

You can use the menus for the audio language, subtitle language, profile, etc. DVD menu contents differ from disc to disc.

1

Press the **Menu** button during playback.

2

Use the **Up/Down** (▲ / ▼) or **Left/Right** (◀ / ▶) button to access the different features.

3

Press the **Enter** button.

- The Menu Screen appears.
- When playing a VCD version 2.0, you can operate it using PBC On/Off function.
- The selected item will play.

Using the Title Menu

For DVDs containing multiple titles, you can view the title of each movie. Depending on the disc, this function may either not work at all, or may work differently.

A↔B Repeat Playback

- 1 Press the **Repeat A↔B** button at the beginning (A) of the segment you want to review.
- 2 Press the **Repeat A↔B** button again at the end (B) of the segment you want to review.
 - The segment will begin repeating.

To return to normal playback

Press the **Repeat A↔B** button again.

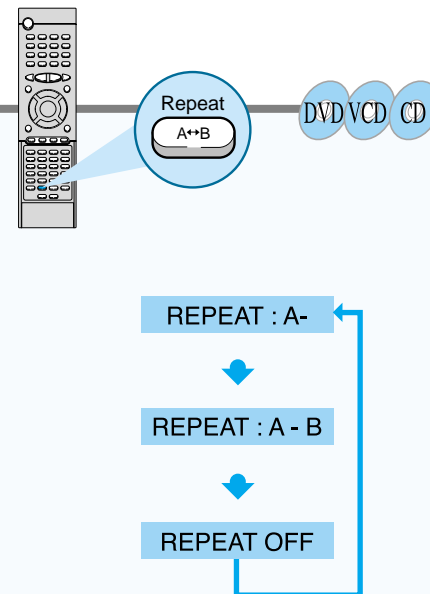

To move directly to a title, chapter, or time

1

Press the **Go To** button.

2

Press Number(0~9) button or the **Left/Right** (◀ / ▶) button.

- Each time the button is pressed, it repeats as shown below.
- Each time the buttons are pressed the desired scene is located and then played.
- Depending on the disc, the Title function may not work.

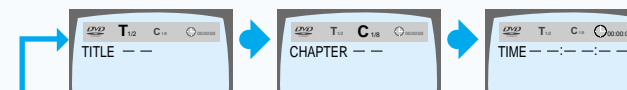

Selecting the Audio Language/Subtitle Language

Zoom/Angle Functions

Selecting the Audio Language

Press the Audio button.

- Depending on the number of languages recorded on a DVD disc, a different audio language (ENGLISH, SPANISH, FRENCH, etc.) is selected each time the button is pressed.

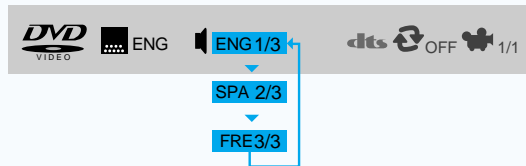

- Note**
- Depending on the disc, DTS or DIGITAL PRO LOGIC can be selected.

Selecting the Subtitle Language

Press the Subtitle button.

- Depending on the number of languages recorded on a DVD disc, a different subtitle language (ENGLISH, SPANISH, FRENCH etc.) is selected each time the button is pressed.
- To make the subtitles disappear, select "OFF".

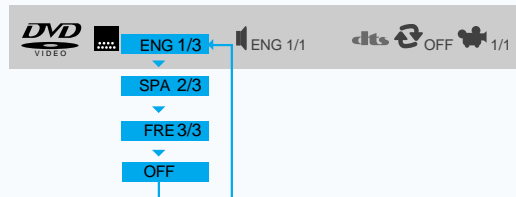

- Note**
- If the word $\text{\textcircled{X}}$ INVALID appears on the TV screen while buttons are being operated, that operation is not possible with that particular disc.
 - Depending on the disc, the audio or subtitle language function may not work.

To enlarge an image

Press the Zoom button.

- Images can be enlarged 2x and 4x.
- During DVD playback, press the **Zoom** button to zoom in 2X/4X/normal, in that order.
- Press \leftarrow / \rightarrow / \uparrow / \downarrow to move the enlarged portion you want to watch.

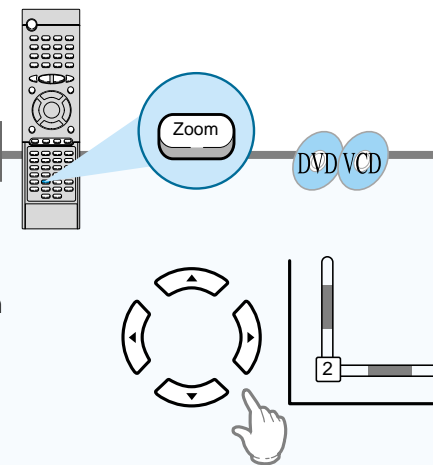

- Note**
- Only 2X zoom operation is possible during VCD playback.

Selecting the desired Screen Angle

Press the Angle button.

- This function only works with discs on which multiple angles have been recorded.
- During playback, press the **Angle** button to select the desired angle: 1/3, 2/3, 3/3, normal, in that order.

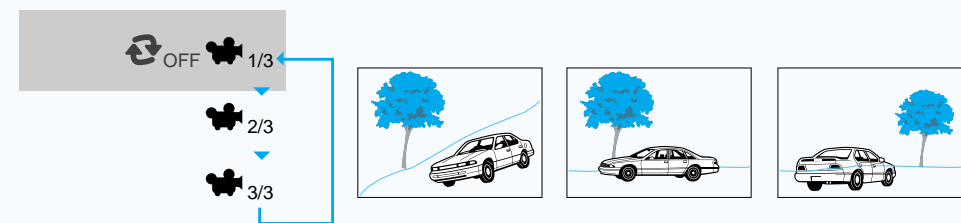

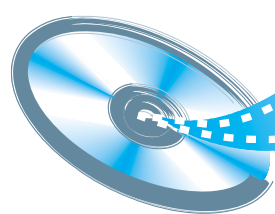

Program Playback

Use this function with video and music CDs to play the tracks in a particular order.

To Program Tracks in a particular order

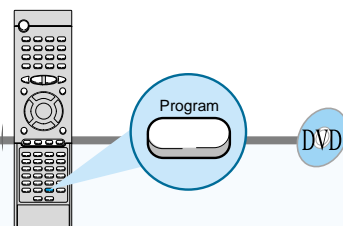

1

Press the **Program** button.

2

Press the **Enter** button then use the Number buttons to select the desired title.

3

Press the **Enter** button, then use the Number buttons to select the desired chapter.

- You can use also just the **Up/Down/Left/Right** (◀/▶/▲/▼) button.
- You can use also just the **Up/Down/Left/Right** (◀/▶/▲/▼) button.

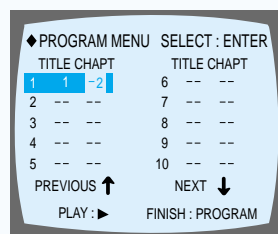
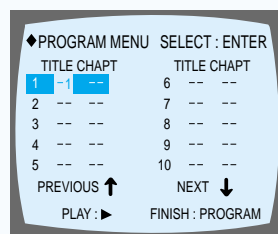
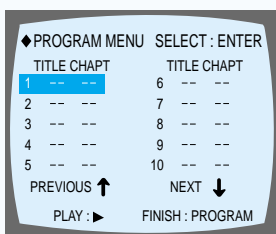

4

Press the **Enter** button.

5

At this time, you can continue programming if you want to.

- The selected track number is programming and the cursor moves to the next number.
- When programming more than 10 tracks, select **NEXT** and then press the **Enter** button. The program selection screen where you can program up to 10 additional tracks appears.

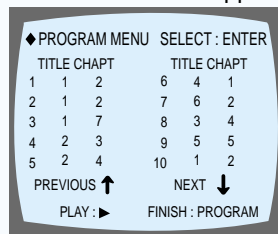
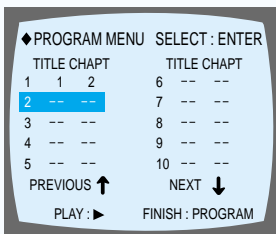

To Playback the Tracks in the Programmed Order



Press the **Play/Pause** (▶||) button.

To Cancel the Programming

- Press either the **Program** button or **Stop** (■) button.

To Change the Program



1

Press the **Up/Down** (▲/▼) button to select the track number to be changed.

2

Press the **Enter** button to select the title or chapter to be changed.

3

Press the **Clear** button and then press the Number buttons.

- The cursor moves to the next number when the **Enter** button is pressed again.
- You can use also just the **Left/Right** (◀/▶) button.

4

Press the **Enter** button.

5

Repeat steps 1-4 above to change the program.

- The cursor moves to the number below.

To delete the entire Program

- Press the **Stop** (■) button twice during playback.
- Press the **Stop** (■) button once when in the Stop mode.
- Press the **Open/Close** (▲) button on the main unit. The disc tray will open and then close. The program will then be deleted.

When you have entered a wrong number

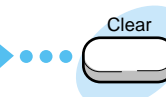

Note You can program or change particular tracks for VCD or CD discs in the same manner.

Press the **Clear** button.

- When you want to delete a selection during programming, select the track (or chapter, or title) to be deleted and then press the **Clear** button.

Sleep/D.R.C Function

Setting up the Language Features

To set up Sleep

Press the Sleep button.

- Each time the button is pressed the selection toggles as follows: SLEEP 10 → SLEEP 20 → SLEEP 30 → SLEEP 60 → SLEEP 90 → SLEEP 120 → SLEEP 150 → OFF.

To Review Sleep Setting

- Press the Sleep button. The remaining time for the selected Sleep time is displayed on the front panel.
- Pressing the button once again changes the Sleep time from the last setting.

What is the Sleep function?
You can set the sleep time so that the unit powers off automatically after a preset period of time.

Activating Dynamic Range Compression

You can enjoy a powerful sound even at a low volume level by compressing the dynamic range (difference between the maximum and minimum sounds).

From the remote control ONLY:

Press the D.R.C button.

- Each time you press the button, the dynamic range compression mode alternates between on and off. Select "D.R.C.ON" while watching the DVD at night. (You can obtain a powerful sound at a low volume.)

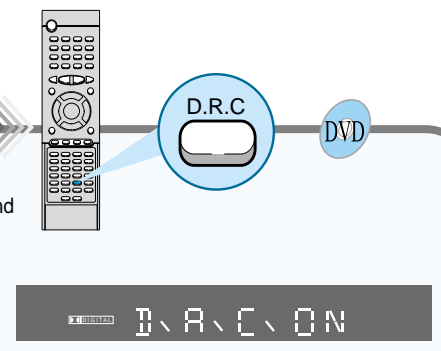

Note • When the Stop button is pressed, DRC is switched to Off.

Using the DVD player's Setup function, you can customize the Menu Language, Subtitle Language, and Disc Menu Language.

To set up the language feature

1 Press the **Setup** button from the stop mode.

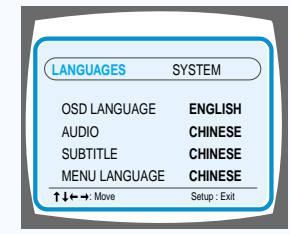

2 Press the **Up/Down** (▲/▼) button to select the desired item.

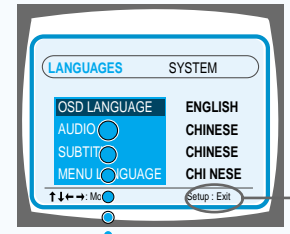

If the **Setup/P.Adj** button is pressed during the language setup, it returns to the stop mode again.

3 Press the **Enter** button or **Right** (▶) button.

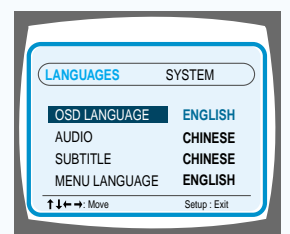

4 Press the **Up/Down** (▲/▼) button to select the desired language and then press the **Enter** button.

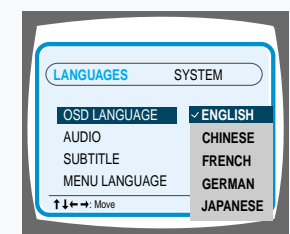

To End the Language Features Setup

- Press the **Setup** button again.

System Setup

You can use the DVD player's Setup function to select the TV screen ratio, rating limit, or digital output mode.

To Set up the System

1

From the stop mode, press the **Setup** button.

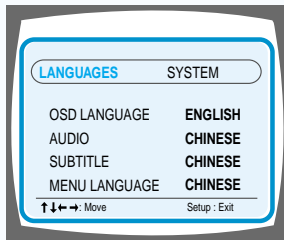

2

Press the **Left/Right** (◀ / ▶) button to select the system.

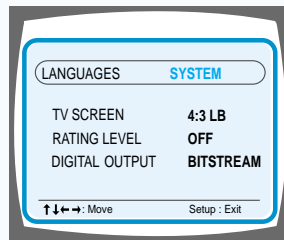

3

Press the **Up/Down** (▲ / ▼) button to select the desired item.

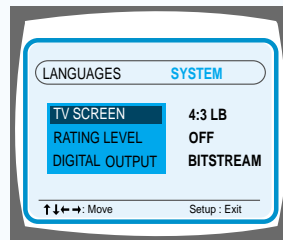

4

Press the **Enter** button or Right (▶) button.

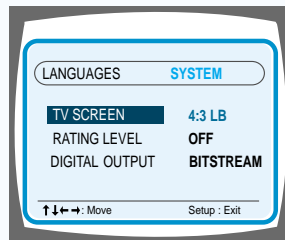

5

Press the **Up/Down** (▲ / ▼) button to select the desired sub-item and then press the **Enter** button.

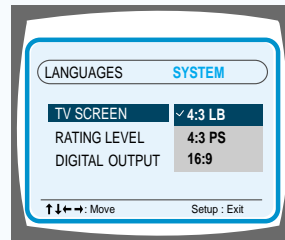

To End the System Setup

- Press the **Setup** button again.



Adjusting the TV Aspect Ratio (Screen Size)

The horizontal to vertical screen size ratio of conventional TVs is 4:3 while that of wide screen and high definition TVs is 16:9. This ratio is called the aspect ratio. When playing DVDs recorded in different screen size, you should adjust the aspect ratio to fit your TV or monitor.

★ For a standard TV, select either "4:3LB" or "4:3PS" option according to personal preference. Select "16:9" if you have a wide screen TV.

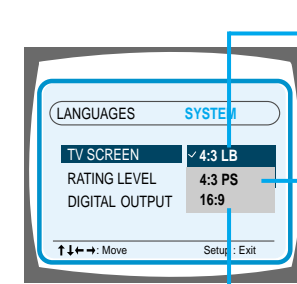

4:3LB
(4:3 Letterbox)

: Select this to play a 16:9 picture in the letter box mode on a conventional TV.
•Black bars will appear at the top and bottom of the screen.



4:3PS
(4:3 Pan&Scan)

: Select this to play a 16:9 picture in the pan & scan mode on a conventional TV.
•You can see the central portion of the screen only (with the sides of the 16:9 picture cut off).



16:9

: Select this to view a 16:9 picture in the full-screen mode on your wide screen TV.
•You can enjoy the wide screen aspect.



Note

- However, if a picture is stored on the DVD in the 4:3 ratio, you cannot view it in wide screen.
- Since DVD discs are recorded in various image formats, they will look different depending on the software, the type of TV, and the TV aspect ratio setting.

RATING LEVEL

The Rating Level function works in conjunction with DVDs which have been assigned a rating, to help control the types of DVDs that your family watches.

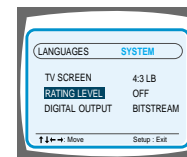

1. Select **RATING LEVEL**, then press the **Enter** button.

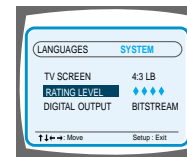

2. Use the number(0~9) buttons to input a 4-digit password.

- The player's password is set to "7890" by default.

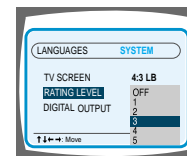

3. Use the **Up/Down** (▲ / ▼) button to select either **RATING LEVEL** or **NEW PASSWORD**, and then press the **Enter** button.

- There are up to 8 rating levels on a disc.
- If LEVEL 6 is selected, a disc which contains rating LEVEL 7 and above cannot be played.
- If you select **NEW PASSWORD**, the screen changes and enables you to enter the new password.

When the rating level password has been forgotten

While the player is in the stop mode, hold the Stop (■) button down on the main unit for more than 5 seconds.

- "INITIAL" appears on the display and all default settings will return to Factory Preset.
- Press the **Power** button.

Speaker Setup

Setting up Speaker Mode and Delay Time

1

Press the SPK Mode button.

2

Press the **Left/Right** (◀/▶) button to select the desired item.

- Each time the button is pressed, a different mode selection is displayed on the front panel display as shown below.

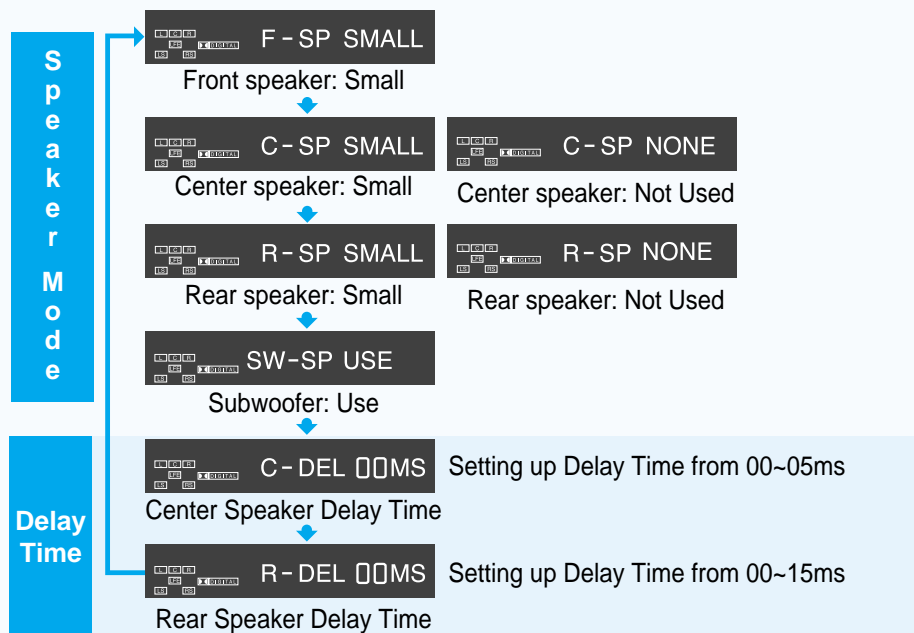

- SMALL: When this setting is selected, low frequencies of below 200 Hz are assigned to the subwoofer only.
- USE: Select when using speakers.
- NONE: Select this when no speakers are installed.

Note The display changes depending on the current audio output mode (DSP, PRO LOGIC, 3-STEREO, STEREO, etc.).

Setting up the Speaker Delay Time

When 5.1CH Surround Sound is played, you can enjoy the best sound if the distance between you and each speaker is the same. Since the sounds arrive at the listening position at different times depending on the placement of speakers, you can adjust this difference by adding a delay effect to the sound of the Center Speaker and Surround Speakers.

Setting CENTER SPEAKER

If the distance of Dc is equal to or longer than the distance of Df in the figure, set the mode as 0ms. Otherwise, change the setting according to the table.

Distance between Df and Dc	Delay Time
50	1.3 ms
100	2.6 ms
150	3.9 ms
200	5.3 ms

Setting REAR (SURROUND) SPEAKERS

If the distance of Df is equal to the distance of Ds in the figure, set the mode as 0ms. Otherwise, change the setting according to the table.

Distance between Ds and Dc	Delay Time
200	5.3 ms
400	10.6 ms
600	15.9 ms

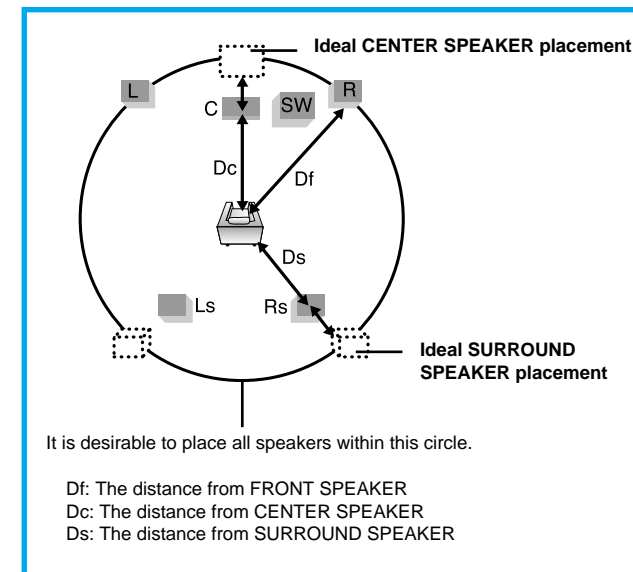

Note Speaker delay time setting is a professional sound volume adjustment method for audio enthusiast. For home use, refer to "Setting up the Ideal Speaker Positions" below to install speakers in appropriate locations.

Ideal Speaker Placement

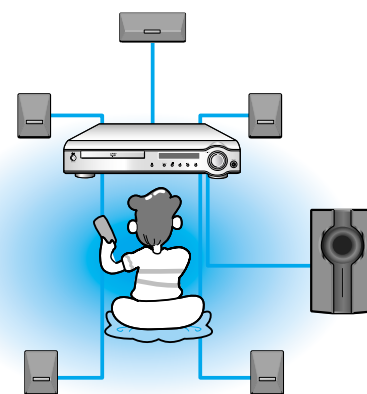

Front Speakers ● ● ●

Set the front speakers so that their tweeters (high-range) are aligned at about ear level and at a horizontal angle of 45° to the prime listening position.

Center Speaker ● ● ●

Ideally the center speaker should be positioned with its top surface flush with the front speakers. However, you may place the speaker either on top or near the bottom of your TV set.

Rear Speakers ● ● ●

Set the rear speakers further back parallel to the walls, at 60 to 90 centimeters (2 to 3 feet) above prime listening position ear level.

If the space behind the listening position is insufficient (i.e., too close to the wall), place the rear speakers facing each other on either side.

Subwoofer Speaker ● ● ●

Place the subwoofer at any convenient location within the vicinity of the listening position.

To set up Speaker Balance

Creating Realistic Sound Fields

To set up Speaker Balance

1

Press the **Sound Edit** button.

- Each time the button is pressed, the selection switches as shown below.

Example: 5.1CH Sound Setup

Front Speakers: L level, R level OFF, range of -6 ~ 0

Rear Speakers: L level, R level OFF, range of -6 ~ 0

Center Speaker CEN +00dB range of -6 ~ -00 ~ +6

Rear Speakers REAR +00dB range of -6 ~ -00 ~ +6

Subwoofer Speaker SW +00dB range of -6 ~ -00 ~ +6

2

Use the **Left/Right** (◀/▶) button to make adjustment.

Note The display changes depending on the current audio output mode (DSP, PRO LOGIC, 3-STEREO, STEREO, etc.).

Speaker Setting Methods

Press the **Test Tone** button.

- The test signal will be sent to the Left Front → Center → Right Front → Right Rear → Left Rear → Subwoofer in that order.

To End the Language Features Setup

- Press the **Test Tone** button again.

Note While in DSP or PRO LOGIC mode, TEST TONE may operate differently for VCDs or CDs.

You can use the following surround modes to reproduce a realistic sound field.

- Digital Multichannel Surround —Dolby Digital and DTS Digital Surround
- Dolby Pro Logic II

Dolby Digital and DTS Digital Surround

To enjoy surround effectively, all the speakers need to be connected and activated.

Dolby Digital

Used to reproduce multichannel sound tracks of the software encoded with Dolby Digital ().

Dolby Digital encoding method (discrete 5.1 channel digital audio format) records and digitally compresses the left front channel, right front channel, center channel, left rear channel, right rear channel, and LFE channel signals (total 6 channels, but LFE channel is counted as 0.1 channel. Therefore, LFE is called the 5.1 channel).

In addition, Dolby Digital enables stereo rear sounds, and sets the cutoff frequency of the rear treble at 20 kHz, compared to 7 kHz for Dolby Pro Logic. These facts result in better sound quality than Dolby Pro Logic.

When the system detects Dolby Digital signals, the DOLBY DIGITAL indicator lights up on the display.

DTS Digital Surround

Used to reproduce multichannel sound tracks of the software encoded with DTS Digital Surround ().

DTS Digital Surround is another discrete 5.1 channel digital audio format available on CD, LD, and DVD software.

Compared to Dolby Digital, audio compression rate is relatively low.

This fact allows DTS Digital Surround format to add breadth and depth to the reproduced sounds. As a result, DTS Digital Surround features natural, solid and clear sound.

When the system detects DTS Digital Surround signals, the DTS indicator lights up on the display.

Dolby Pro Logic II

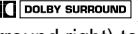
- Dolby Pro-Logic II is a new multi-channel playback format developed by Dolby Laboratories using feedback logic steering technology and offering improvements over conventional Dolby Pro Logic circuits.
- Dolby Pro Logic II can be used to decode not only sources recorded in Dolby Surround () but also regular stereo sources into five channels (front left, front right, center, surround left and surround right) to achieve surround sound.
- Whereas with conventional Dolby Pro Logic the surround channel playback frequency band was limited, Dolby Pro Logic II offers a wider band range. In addition, the surround channels were monaural (the surround left and right channels were the same) with previous Dolby Pro Logic, but with Dolby Pro Logic II they are stereo.

* Sources recorded in Dolby Surround

These are sources in which three or more channels of surround have been recorded as two channels of signals using Dolby Surround encoding technology.

Dolby Surround is used for the sound tracks of movies recorded on DVDs, LDs and video cassettes to be played on stereo VCRs, as well as for the stereo broadcast signals of FM radio, TV, satellite broadcasts and cable TV.

Decoding these signals with Dolby Pro Logic makes it possible to achieve multi-channel surround playback.

The signals can also be played on ordinary stereo equipment, in which case they provide normal stereo sound.

Manufactured under license from Dolby Laboratories. "Dolby," "Pro Logic," and the double-D symbol are trademarks of Dolby Laboratories. Confidential Unpublished Works. ©1992-1997 Dolby Laboratories, Inc. All rights reserved.

Manufactured under license from Digital Theater Systems, Inc. US Pat. No. 5,451,942 and other world-wide patents issued and pending. "DTS" and "DTS Digital Surround" are trademarks of Digital Theater Systems, Inc. ©1996 Digital Theater Systems, Inc. All rights reserved.

Dolby Pro Logic II decoder

Dolby Pro Logic II

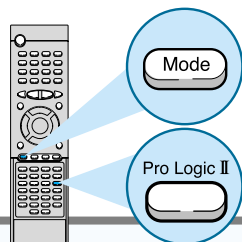

DVD VCD CD

Dolby Pro Logic II is a new format for playing multichannel audio signals that offers improvements over conventional Dolby Pro Logic. It can be used to decode not only sources recorded in Dolby Surround, but also regular stereo sources into five channels (front left/right, center and surround left/right). In addition, various parameters can be set according to the type of source and the contents, so you can adjust the sound field with greater precision.

1

Press the **Function** button on the front panel to select the desired function.

- Select from FM → AM → DVD → DIGITAL IN → AUX 1 → AUX 2.

2

Press the **Pro Logic II** button.

- Each time the **Pro Logic II** button is pressed.

3

Press the DSP/DPL II **Mode** button.

- Each time the DSP/DPL II **Mode** button is pressed.

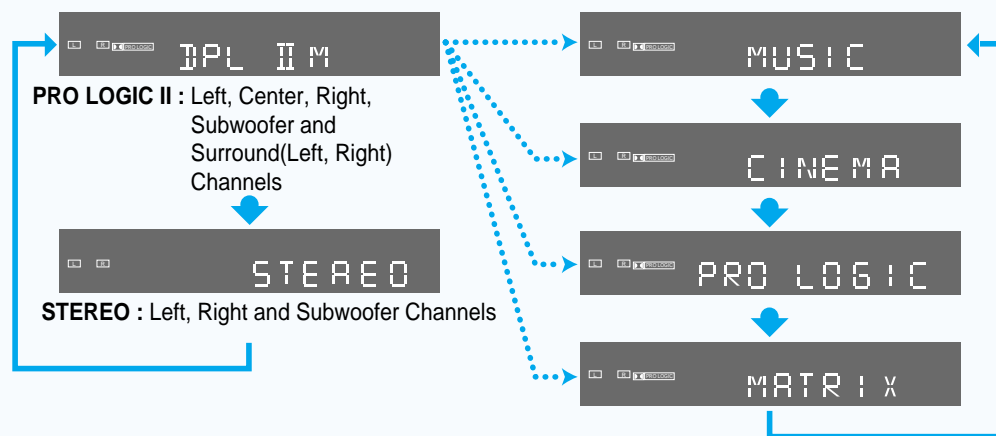

Pro Logic II Mode

Select one of the modes (“MUSIC”, “CINEMA”, “PRO LOGIC” or “MATRIX”).

- The Music mode is recommended when listening to CDs or watching DVDs with mostly musical content.
- The Cinema mode is best when watching movies.
- The Pro Logic mode offers the same surround processing as original Pro Logic and is best used when the source contents are not of optimum quality.
- The Matrix mode is useful for when the audio is mono.

Dolby Pro Logic II Effect Function

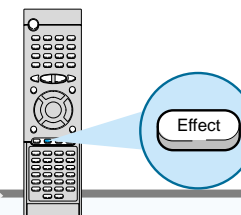

This function works only in the DPL II M (Dolby Pro Logic II **Music**) Mode.

1

Press the DSP/DPL II **Effect** button.

2

Use the **Left/Right** (◀/▶) button to make adjustments.

- Each time the DSP/DPL II **Effect** button is pressed.

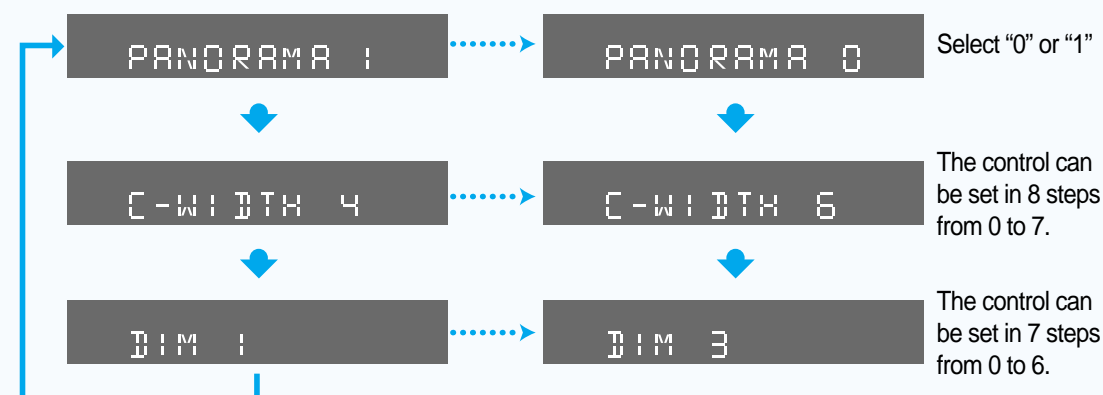

• Panorama Mode

This mode extends the front stereo image to include the surround speakers for an exciting “wraparound” effect with side wall imaging.

• Center Width Control

This control adjusts the center image so it may be heard only from the center speaker; only from the left/right speakers as a phantom image; or from all three front speakers to varying degrees.

• Dimension Control

This control gradually adjusts the soundfield either towards the front or towards the rear.



- When playing a DVD encoded in two or more channels, DOLBY PRO LOGIC II mode cannot be selected.

DSP (Digital Signal Processor) Modes

DSP modes have been designed to simulate different acoustic environments. The sound heard in a hall, theater, pavilion, dance club, or live club consists of direct and indirect sound—early reflections and reflections from behind. Direct sounds reach the listener directly without any reflection. Indirect sounds are delayed by the distance of the ceiling and walls. These indirect sounds are an important element of the acoustic surround effect.

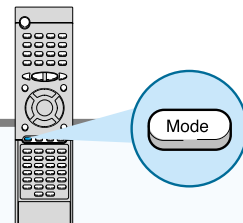

Press the DSP/DPL II Mode button.

- This function works only in the STEREO Mode.

- The following DSP modes are provided with this unit:

- HALL** Provides a clear vocal and simulates the feeling of a concert hall.
- ↓
- THEATER** Simulates the feeling of a theater.
- ↓
- PAVILION** Simulates the spacious feeling of a pavilion with a high ceiling.
- ↓
- DANCE CLUB** Simulates the sound of a dance club with a throbbing bass beat.
- ↓
- LIVE CLUB** Simulates the feeling of a live music club with a low ceiling.

- These DSP modes can be used to add acoustic surround effects while reproducing stereo analog or linear PCM digital signals.
- When one of the DSP modes is selected, the DSP indicator lights up on the display.

DSP modes available according to the input signal format

O : Possible, X : Not possible

Input Signal format	Surround	Multichannel Surround	DSP					(canceled)
			HALL	THEATER	PAVILION	DANCE CLUB	LIVE CLUB	STEREO
Input Signal format	Analog	X	O	O	O	O	O	O
	Linear PCM	X	O	O	O	O	O	O
	Dolby Digital	O	X	X	X	X	X	X
	DTS	O	X	X	X	X	X	X

To increase Effect level

To increase Effect level

Press the DSP/DPL II **Effect** button.

- The effect level can be set in steps from 1 to 4 EFFECT1 → EFFECT2 → EFFECT3 → OFF (DEFAULT). Each time the button is pressed the selection moves to the next effect.
- The higher the number, the stronger the DSP surround effect will be.

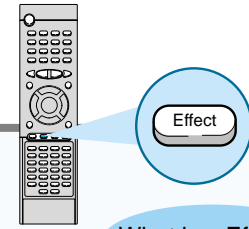

What is a Effect?

This sets the strength of the DSP mode.

- Note** • This function works only in the DSP Mode.

Adjusting DSP Sound Parameters

You can fine-adjust DSP modes more minutely by changing three parameters—room, liveness, and reverberation.

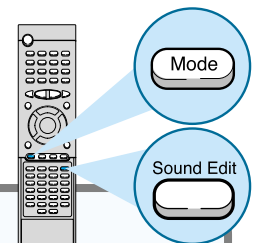

1 Press the DSP/DPL II **Mode** button.

2 Press the **Sound Edit** button.

- Each time you press the button, the indication on the display changes as follows:

3 Press the **Left/Right** (◀ / ▶) button to adjust the DSP sound parameter.



ROOM : To adjust the resonance based on the room size. The larger this value is, the more effective the resonance is (from 04 to 16 by 2 steps).

LIVE (Liveness) : To adjust the liveness. The larger this value is, the more liveness is obtained (from 04 to 16 by 2 steps).

REVERB (Reverberation) : To adjust the reverberation time of the sound (from 0.0 msec to 1.6 msec by 0.2 msec steps).

- Note** • This function works only in the DSP Mode.

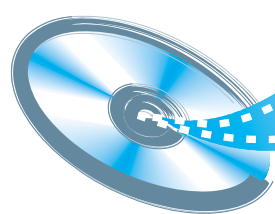

Listening to the Radio

You can listen to the chosen band (FM, MW or LW broadcast stations) by using either the automatic tuning or manual tuning operation.

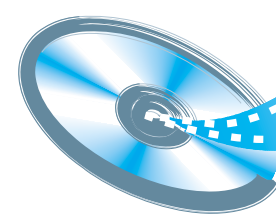

Presetting stations

You can store up to:

- ◆ 15 FM stations
 - ◆ 8 MW stations
 - ◆ 7 LW stations
- **FM** Frequency Modulation
 - **AM(MW)** Medium Wave
 - **LW** Long Wave

Remote Control Unit

1

Press the **Tuner(Band)** button.

- The selection toggles back and forth between "FM" "MW" and "LW" each time the **Tuner(Band)** button is pressed.

2

Select a broadcast station.

- Auto Station 1** When the **I◀▶I** button is pressed, a preset broadcast station is selected.
- Auto Station 2** Hold in the **◀▶** button. Automatic searching begins, and then stops when a station is tuned in.
- Manual Station** Press the **◀▶** button to tune to the chosen station. The frequency changes incrementally in either direction each time the corresponding button is pressed.

1

Press the **Function** button to select the desired band (FM, MW or LW).

Main Unit

2

Select a broadcast station.

- Auto Station 1** Press the **Stop (■)** button to select the PRESET mode. Then press the **I◀▶I** button to select a station stored in the preset
- Auto Station 2** Press the **Stop (■)** button to select the MANUAL mode on the front panel. Then hold in the **I◀▶I** button to make the unit begin automaticall searching for broadcast stations.
- Manual Station** Press the **Stop (■)** button to select the MANUAL mode front panel. Press the **I◀▶I** button to tune to the desired station. The frequency changes incrementally in either direction each time the corresponding button is pressed.

To Listen in Mono/Stereo



Press the MO/ST button. (only FM)

- The selection toggles back and forth between "STEREO" and "MONO" each time the **MO/ST** button is pressed.
- In a poor reception areas, select Mono mode for a clear, interference-free broadcast.

Example: Presetting FM 89.1 in the memory

1

Press the **Tuner(Band)** button and select the FM band.

2

Select the MANUAL by pressing the **Stop (■)** button on the main unit.

3

Use the **◀▶** and **▶▶** button to tune into 89.1

- The selection toggles back and forth between " **FM** → **AM(MW)** → **LW** " each time the **Tuner(Band)** button is pressed.



4

Press the **Program** button on the remote control, FM1 will flash. If you want to save 89.1 to FM1, press Program again.

5

If you want to save 89.1 to another preset location(FM2~FM15), press **I◀▶** or **▶▶I**, then press **Program** to save it to that location.

6

To preset other stations, follow steps 1~5 again.

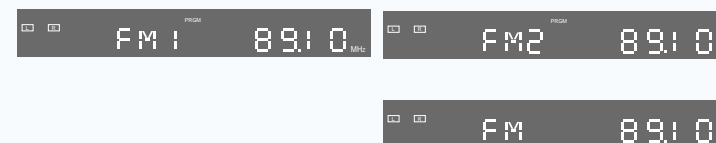

To tune in a preset station

See the previous page.

About RDS broadcasting

Using the RDS (Radio Data System) to receive FM stations

RDS allows FM stations to send an additional signal along with their regular program signals. For example, the stations send their station names, as well as information about what type of program they broadcast, such as sports or music, etc.

When tuned to an FM station which provides the RDS service, the RDS indicator lights up on the display.

- Description on RDS function
 - PTY (Program Type)** : Displays the type of programme currently being broadcast
 - PS NAME (Program Service Name)** : Indicates the name of broadcasting station and is composed of 8 characters.
 - RT (Radio Text)** : Decodes the text broadcast by a station (if any) and is composed of maximum 64 characters.
 - CT (Clock Time)** : Decodes the real time clock from the FM frequency.
 - Some stations may not transmit PTY, RT or CT information therefore this may not be displayed in all cases.
 - TA (Traffic Announcement)** : When this symbol flashes it shows that the traffic announcement is in progress.

Note

- RDS is not available for MW/LW broadcasts.
- RDS may not operate correctly if the station tuned is not transmitting RDS signal properly or if the signal strength is weak.

What information can RDS signals provide?

You can see the RDS signals the station sends on the display.

TO show the RDS signals

Press **RDS DISPLAY** while listening to an FM station.

Each time you press the button, the display change to show you the following information:

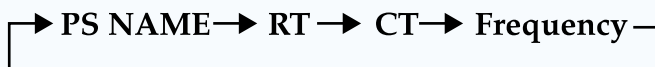

PS (Program Service) : While searching, "PS" appears and then the station names will be displayed. "NO PS" appears if no signal is sent.

RT (RadioText) : while searching, "RT" appears and then text messages the station sends will be displayed. "NO RT" appears if no signal is sent.

Frequency : station frequency (non-RDS service)

About characters shown in the display

When the display shows PS, or RT signals, the following characters are used.

- The display window cannot differentiate upper case and lower case letters and always uses upper case letters.
- The display window cannot show accented letters, "A," for instance, may stand for accented "A's" like "Ä, Å, Ä, Å, and Ä."

Note

If searching finishes at once, "PS", and "RT" will not appear on the display.

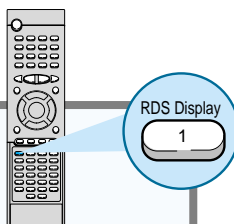

PTY (Program Type) indication and PTY-SEARCH function

One of the advantages of the RDS service is that you can locate a particular kind of program from the preset channels by specifying the PTY codes.

To search for a program using the PTY codes

Before you start, remember...

- The PTY Search is only applicable to preset stations.
- To stop searching any time during the process, press PTY SEARCH while searching.
- There is a time limit in doing the following steps. If the setting is cancelled before you finish, start from step 1 again.
- When pressing the buttons on the primary remote control, make sure that you have selected the FM station using the primary remote control.

- Press PTY SEARCH while listening to an FM station.
- Press and hold PTY- or PTY+ until the PTY code you want appears on the display window, while "PTY SELECT" is flashing.
 - The display gives you the PTY codes described to the right.
- Press PTY SEARCH again, while the PTY code selected in the previous step is still on the display.
 - The center unit searches 15 preset FM stations, stops when it finds the one you have selected, and tunes in that station.

Display	Program Type
NEWS	• News including an announced opinion and report
AFFAIRS	• Several matters including a current incident, documentary, discussion and analysis.
INFO	• Information including weights and measures, returns and forecast, matters interesting the customer, medical information, etc.
SPORT	• Sports
EDUCATE	• Education
DRAMA	• Drama-Radio serial, etc.
CULTURE	• Culture-National or local culture including the religious problem, social science, language, theater, etc.
SCIENCE	• Natural science and technology
VARIED	• Others-Speech, amusing program (quiz, game), interview, comedy and satirical play, etc.
POP M	• Pop music
ROCK M	• Rock music
M.O.R.M	• Current contemporary music considered to be "easy listening."
LIGHT M	• Light classical music- Classical music and instrumental and chorus music
CLASSIC	• Heavy classical music-Orchestra music, symphony, chamber music and opera
OTHER M	• Other music - Jazz, R&B country music
WEATHER	• Weather
FINANCE	• Finance
CHILDREN	• Children's programmes
SOCIAL A	• Social affairs
RELIGION	• Religion
PHONE IN	• Phone in
TRAVEL	• Travel
LEISURE	• Leisure
JAZZ	• Jazz Music
COUNTRY	• Country Music
NATIONAL M	• National Music
OLDIES	• Oldies Music
FOLK M	• Folk Music
DOCUMENT	• Documentary

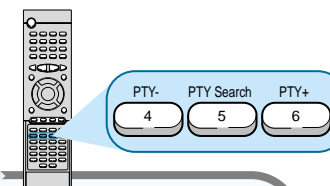



Troubleshooting

Problem	Check
The disc tray does not open.	<ul style="list-style-type: none"> • Is the disc installed with the label side facing up? • Is the power cord plugged securely into the power outlet? • Turn off the power to the unit by pressing the Power (⏻) button and turn it back on.
Disc does not play.	<ul style="list-style-type: none"> • Check the region number of the DVD. • DVD discs purchased abroad may not be playable. • This player cannot play CD-ROMs, DVD-ROMs, etc. • Check the rating level of the DVD.
Playback does not start immediately when the Play/Pause button is pressed.	<ul style="list-style-type: none"> • Check whether the disc has any scratch marks or is deformed?
No sound is produced.	<ul style="list-style-type: none"> • No sound is heard during high-speed playback, slow playback, and step motion playback modes. • Are the speakers properly connected? Is the speaker Setup correctly customized? • Is the disc severely damaged? The disc may be dirty. Wipe off fingerprints or dirt.
Sound can be heard only from a few speakers and not all six.	<ul style="list-style-type: none"> • When listening to a CD or radio, sound is output to the front speakers only (L/R). Select the "PRO LOGIC" option by pressing the Pro Logic button on the remote control unit to use all six speakers. • Check whether your DVD disc is 5.1 CH compatible.
Picture does not appear; sound is not produced; the disc tray opens 2-5 seconds later.	<ul style="list-style-type: none"> • Was the player moved suddenly from a cold place to a warm one? When condensation forms inside the player, remove the disc and let the player stand for 1 or 2 hours with the power on. (You can use the player after the condensation disappears.)
Sound quality is irregular.	<ul style="list-style-type: none"> • Are the speaker cables loose? • Is there any dirt or debris at the end of the speaker connector?
Dolby Digital 5.1 Channel Surround Sound is not being reproduced.	<ul style="list-style-type: none"> • Does the disc being played show the "Dolby Digital 5.1CH" mark? 5.1-channel sound is reproduced only if the disc is recorded with 5.1 channel sound. • Is the DVD player connected to the proper speakers?

Problem	Check
<ul style="list-style-type: none"> • The disc revolves but no picture appears. • Picture shows interference and quality is poor. 	<ul style="list-style-type: none"> • Is the TV power turned on? • Are the video cables properly connected? • Is it the player in PAUSE mode? • Is your TV's video format (NTSC/PAL) set correctly? Press the NTSC/PAL button once again to change the current selection. • Is there any dirt on the disc, or is the disc damaged? • It may not be possible to play some DVD discs due to poor manufacture. • When a dark scene changes to a bright scene during playback, the screen may flicker vertically. Some disturbance is normal.
Remote control unit does not operate.	<ul style="list-style-type: none"> • Is the remote control being used within the appropriate distance and angle of operation for the unit? • Are there any obstacles between the remote control unit and the remote control sensor? • Are the batteries dead? Is it time to replace the batteries with new ones?
Audio or subtitle language does not operate.	<ul style="list-style-type: none"> • The audio or subtitle language features does not operate with DVDs that do not include multiple audio or subtitle languages.
The Menu button is pressed but the Menu screen does not appear.	<ul style="list-style-type: none"> • Is the remote control being used within the appropriate distance and angle of operation for the unit? • Are the batteries dead? • Does the disc have a Menu?
The screen ratio cannot be changed.	<ul style="list-style-type: none"> • You can play 16:9 wide DVDs in 16:9 WIDE mode, 4:3 LETTER BOX mode or 4:3 PAN-SCAN mode; but 4:3 encoded DVDs only show in 4:3 ratio. Refer to the DVD disc jacket and then select the appropriate function.
The desired radio station cannot be tuned in.	<ul style="list-style-type: none"> • Is the antenna installed properly? • When the antenna's input signal is weak, install an external FM antenna in an area with good reception quality.
The system is malfunctioning (the system does not work or no sound).	<ul style="list-style-type: none"> • While the player is in the stop mode, hold the Stop (■) button down on the main unit for over 5 seconds. "INITIAL" appears on the display and all settings will return to the Factory Preset condition. The RESET function erases all settings; do not use this function unless necessary.

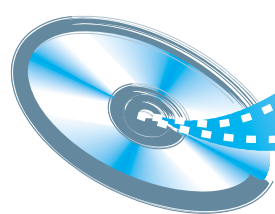

Cautions on Handling and Storing Discs

Small scratches on the disc may reduce sound and picture quality or cause breaks in playback. Be especially careful not to scratch discs when handling them.

Handling and Storing Discs

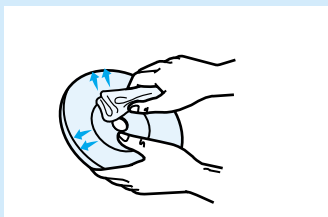

When you get fingerprints or dirt on the disc, clean it with a mild detergent diluted in water and wipe with a soft cloth.

- When cleaning, wipe gently from the inside to the outside of the disc.



Note Condensation may form if warm air comes into contact with cold parts inside the player. When condensation forms inside the player, the player may not operate correctly. If this occurs, remove the disc and let the player stand for 1 or 2 hours with the power on.

Disc Storage

Do not keep in direct sunlight

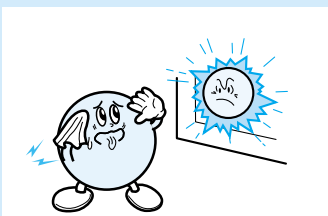

Keep in a cool ventilated area

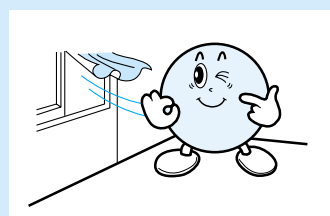

Keep in a clean Protection jacket. Store vertically.

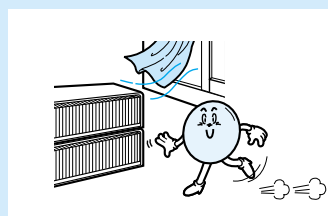

- Do not allow the discs to become contaminated with dirt.
- Do not load cracked discs or discs that are scratched.

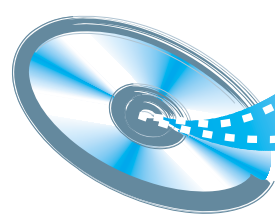

Disc Type and Protection

Usable Discs

Disc Types	Marks	Recording Types	Disc Size	Max. Playing Time
DVD		Audio + Video	12cm	Approx. 240 min. (Single-sided) Approx. 480 min. (Double-sided)
			8cm	Approx. 80 min. (Single-sided) Approx. 160 min. (Double-sided)
VIDEO-CD		Audio + Video	12cm	74 min.
			8cm	20 min.
AUDIO-CD		Audio	12cm	74 min.
			8cm	20 min.



Dolby Digital disc



DTS Disc



Digital Audio disc



Stereo disc



NTSC broadcast system in USA, Canada, Japan, South Korea, etc..



MP3 disc







Specification

GENERAL	Power Consumption	160W		
	Weight	8.3Kg		
	Dimensions (W x H x D)	430mm x 80mm x 365mm		
	Operating Temperature Range	+5°C~+35°C		
	Operating Humidity Range	10%~75%		
FUNCTION	Usable Sensitivity	10dB		
	S/N Ratio	60dB		
	Distortion	0.5%		
AMT	Usable Sensitivity	54dB		
	S/N Ratio	40dB		
	Distortion	2%		
VIDEO	Composite Video	1.0Vp-p(75Ω load)		
	Scart Jack	Compositive Video : 1.0Vp-p(75Ω load)		
		Luminance signal : 1.0Vp-p(75Ω load)		
		Color Signal : 0.286Vp-p(75Ω load)		
	S-VIDEO	Luminance Signal: 1.0Vp-p(75Ω load)		
Color Signal: 0.286Vp-p(75Ω load)				
AMPLIFIER	Front speaker output	60W x 2(6Ω), Distortion 10%		
	Center speaker output	60W(6Ω), Distortion 10%		
	Rear speaker output	60W x 2(6Ω), Distortion 10%		
	Subwoofer speaker output	100W(3Ω), Distortion 10%		
	Frequency range	20Hz~20KHz		
	S/N Ratio	75dB		
	Channel separation	50dB		
	Input sensitivity	(AUX)500mV		
SPEAKER	Speaker system	5.1ch speaker system		
		Front/Center/Rear speaker	Subwoofer speaker	
	Impedance	6Ω x 5	3Ω	
	Frequency range	100Hz~22KHz	40Hz~200Hz	
	Output sound pressure level	87dB/W/M	86dB/W/M	
	Rated input	60W	100W	
	Maximum input	120W	200W	
	Dimensions (W x H x D)	Front/Rear	120mm x 186mm x 145mm	210mm x 367mm x 332mm
		Center	300mm x 139mm x 136mm	
	Weights	Front/Rear	1.2Kg	6.0Kg
Center		1.4Kg		



Reference

Note on Terminology

ANGLE	Recorded onto some DVD discs are scenes which have been simultaneously shot from a number of different angles (the same scene is shot from the front, from the left , from the right , etc.). With such discs, the Angle button can be used to change the angle of view for specific scenes.
CHAPTER NUMBER	These numbers are recorded on DVD discs. A Title is subdivided into many sections, each of which is numbered, and specific parts of the video can be searched quickly using these numbers.
DVD	A high-density optical disc on which high-quality pictures and sound have been recorded by means of digital signals. Incorporating a new video compression technology (MPEG-2) and high-density recording technology, a DVD disc comprises two 0.6 mm thick discs bonded together.
PCM	An acronym for Pulse Code Modulation - another name for digital audio.
PBC (PLAYBACK CONTROL)	This is recorded on a video CD (version 2.0). Selected scenes or information can be chosen from the menu displayed on the TV monitor.
REGION NUMBER	Both the DVD player and DVD discs are encoded with a region number. If the region number on the DVD disc does not correspond to the region number of the DVD player, the player cannot play the disc.
SUBTITLES	Translated appearing at the bottom of the screen. A DVD disc can contain up to 32 subtitle languages.
TITLE NUMBER	These numbers are recorded on DVD discs. When a disc contains two or more movies, these movies are numbered as Title 1, Title 2, etc.
TRACK NUMBER	These numbers are assigned to the tracks which are recorded on video and audio CDs. They enable specific tracks to be located quickly.
VIDEO CD	Contains recordings of pictures and sound whose quality is roughly comparable to that of video tape. This player also supports video CDs with playback control (version 2.0).
	You can enjoy 5.1 (or 6) channels of high fidelity digital sound from various digital input sources such as laser discs, DVD, CD etc. DTS provides a realistic, clear surround sound that has not previously been available from conventional surround sound.
	5.1 (or 6) Channel Digital Surround sound reproduced from DVDs and LDs recorded as a digital signals (with  disc marking). With better sound quality, dynamic range, and directionality than the traditional Dolby surround technology, you can enjoy the dynamic realistic sound.
	A 4 channel analog sound reproduced from a program source such as a videotape or LD with the  mark. You can enjoy a more realistic, robust sound unavailable from regular stereo sources.